

INDEX OF DRAWING	
SHEET NO.	DESCRIPTION
1	COVER PAGE, GENERAL NOTES, GLAZING DETAILS
2 & 2.1	SINGLE & DOUBLE DOORS TYP. ELEVATIONS & CAPACITY
3	SINGLE & DOUBLE DOORS WITH TRANSOM, ELEVATIONS & CAPACITY CHART
4 & 4.1	LOCK OPTIONS & LIMITATIONS
5	HORIZONTAL RAILS, HEAD/SILL DETAILS & TYPICAL ANCHORS
5.1	ADA COMPLIANT THRESHOLD DETAILS
6	VERTICAL STILES, JAMB DETAILS
7	TRANSOM HEAD/SILL/JAMB DETAILS
8	PARTS DRAWINGS
9	BILL OF MATERIALS & HINGE OPTIONS
10	CORNER CONSTRUCTION DETAILS

**SERIES ENV-350  
ALUMINUM INSWING ENTRANCE DOOR**

DOORS NOT APPROVED FOR INSTALLATIONS WHERE WATER INFILTRATION RESISTANCE IS REQUIRED.

THESE DOORS MAY BE USED IN CONJUNCTION WITH F.B.C. APPROVED LARGE MISSILE IMPACT RESISTANT STOREFRONT SYSTEM. LOWER DESIGN PRESSURE FROM DOOR OR STOREFRONT APPROVAL WILL APPLY TO ENTIRE SYSTEM.

CODE REQUIREMENTS FOR SAFEGUARDS MUST BE OBSERVED.

THIS PRODUCT HAS BEEN DESIGNED AND TESTED TO COMPLY WITH THE REQUIREMENTS OF THE 2017 (6TH EDITION) FLORIDA BUILDING CODE INCLUDING HIGH VELOCITY HURRICANE ZONE (HVHZ).

1BY OR 2BY WOOD BUCKS & BUCK FASTENERS BY OTHERS, MUST BE DESIGNED AND INSTALLED ADEQUATELY TO TRANSFER APPLIED PRODUCT LOADS TO THE BUILDING STRUCTURE.

ANCHORS SHALL BE CORROSION RESISTANT, SPACED AS SHOWN ON DETAILS AND INSTALLED PER MANUF'S INSTRUCTIONS. SPECIFIED EMBEDMENT TO BASE MATERIAL SHALL BE BEYOND WALL DRESSING OR STUCCO.

A LOAD DURATION INCREASE IS USED IN DESIGN OF ANCHORS INTO WOOD ONLY.

ALL SHIMS TO BE HIGH IMPACT, NON-METALLIC AND NON-COMPRESSIBLE.

MATERIALS INCLUDING BUT NOT LIMITED TO STEEL/METAL SCREWS, THAT COME INTO CONTACT WITH OTHER DISSIMILAR MATERIALS SHALL MEET THE REQUIREMENTS OF THE 2017 FLORIDA BLDG. CODE & ADOPTED STANDARDS.

THIS PRODUCT APPROVAL IS GENERIC AND DOES NOT PROVIDE INFORMATION FOR A SITE SPECIFIC PROJECT, i.e. LIFE SAFETY OF THIS PRODUCT, ADEQUACY OF STRUCTURE RECEIVING THIS PRODUCT AND SEALING AROUND OPENING FOR WATER INFILTRATION RESISTANCE ETC. CONDITIONS NOT SHOWN IN THIS DRAWING ARE TO BE ANALYZED SEPARATELY, AND TO BE REVIEWED BY BUILDING OFFICIAL.

MANUFACTURER'S LABEL SHALL BE LOCATED ON A READILY VISIBLE LOCATION IN ACCORDANCE WITH SECTION 1709.9.3 OF FLORIDA BUILDING CODE. LABELING TO COMPLY WITH SECTION 1709.9.2.

**INSTRUCTIONS:**

USE DRAWING AS FOLLOWS.

1. SELECT SINGLE OR DOUBLE DOORS FROM SHEETS 2 & 2.1 OR SINGLE OR DOUBLE DOORS WITH TRANSOM FROM SHEET 3.
2. SELECT DOOR AND FRAME SIZE.
3. DETERMINE Dp RATING FROM SHEET 2, 2.1 OR 3.
4. SELECT GLASS TYPE FROM SHEET 1.1.
5. SELECT LOCK OPTION AND CORRESPONDING MAX. DESIGN LOAD FROM SHEET 4 & 4.1.
6. SELECT ANCHORING CONDITION AND CORRESPONDING ANCHOR TYPE AND NUMBER OF ANCHORS FROM SHEET 5.
7. SELECT JAMB OPTIONS FROM SHEET 6.
8. SELECT HINGE OPTION FROM SHEET 9.
9. DETERMINE FINAL DESIGN PRESSURE FOR THE SYSTEM, TAKEN AS THE LOWEST OF ALL Dp VALUES OBTAINED.

DOORS ARE RATED FOR LARGE & SMALL MISSILE IMPACT. SHUTTERS ARE NOT REQUIRED.

- A- CONTRACTOR TO BE RESPONSIBLE FOR THE SELECTION, PURCHASE AND INSTALLATION OF THIS PRODUCT BASED ON THIS PRODUCT EVALUATION PROVIDED HE/SHE DOES NOT DEVIATE FROM THE CONDITIONS DETAILED ON THIS DOCUMENT.
- B- THIS PRODUCT EVALUATION DOCUMENT WILL BE CONSIDERED INVALID IF ALTERED BY ANY MEANS.
- C- SITE SPECIFIC PROJECTS SHALL BE PREPARED BY A FLORIDA REGISTERED ENGINEER OR ARCHITECT WHICH WILL BECOME THE ENGINEER OF RECORD (E.O.R.) FOR THE PROJECT AND WHO WILL BE RESPONSIBLE FOR THE PROPER USE OF THE P.E.D. ENGINEER OF RECORD, ACTING AS A DELEGATED ENGINEER TO THE P.E.D. ENGINEER SHALL SUBMIT TO THIS LATTER THE SITE SPECIFIC DRAWINGS FOR REVIEW.
- D- THIS P.E.D. SHALL BEAR THE DATE AND ORIGINAL SEAL AND SIGNATURE OF THE PROFESSIONAL ENGINEER OF RECORD THAT PREPARED IT.

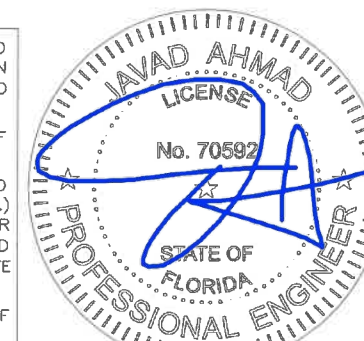

**AL-FAROOQ CORPORATION**  
ENGINEERS & PRODUCT DEVELOPMENT  
9360 SUNSET DRIVE, SUITE 220  
MIAMI, FLORIDA 33173  
TEL. (305) 264-8100 FAX. (305) 262-6978

SERIES ENV-350 INSWING ENTRANCE DOOR (L.M.I.)  
**ENVIRALUM INDUSTRIES INC.**  
5100 N.W. 72 AVENUE BLDG. C  
MIAMI, FL. 33166  
TEL. (305) 752-4411 FAX. (305) 406-3877

revisions:	no	date	by	description
	A	07.06.17		GLASS & LOCK OPTION ADDED
	B	04.17.19		LOCK OPTION ADDED
	C	05.01.19		1/4" ANCHOR OPTION ADDED

date: 04-11-17  
scale: 3/8" = 1"  
dr. by: TARIQ  
chk. by:

drawing no.  
**W17-43**

sheet 1 of 10

COMP-ANL\W17-43ENV

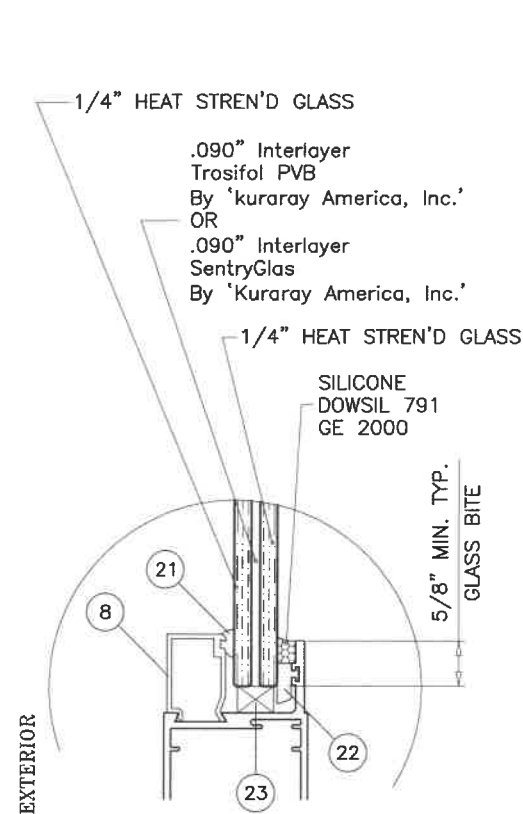

GLASS TYPE 'A'

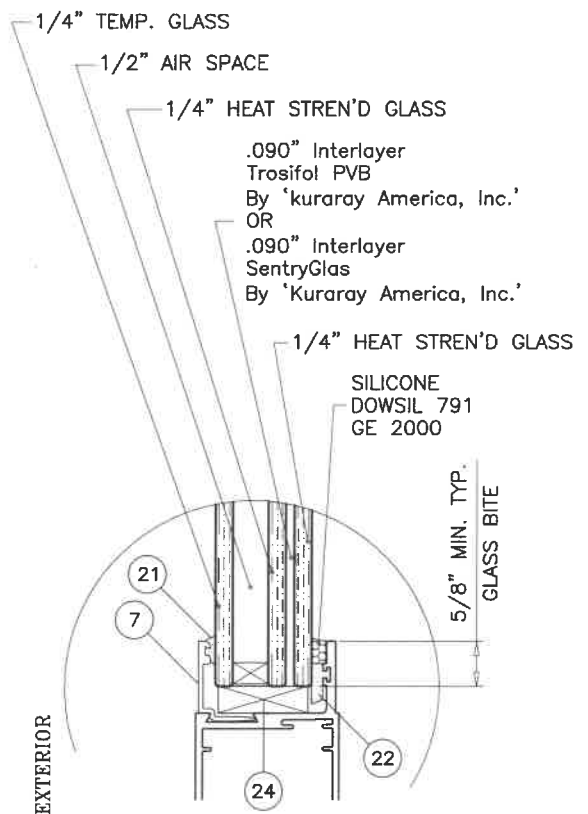

GLASS TYPE 'A1'

GLAZING DETAILS DOOR  
LEVEL 'D' IMPACT

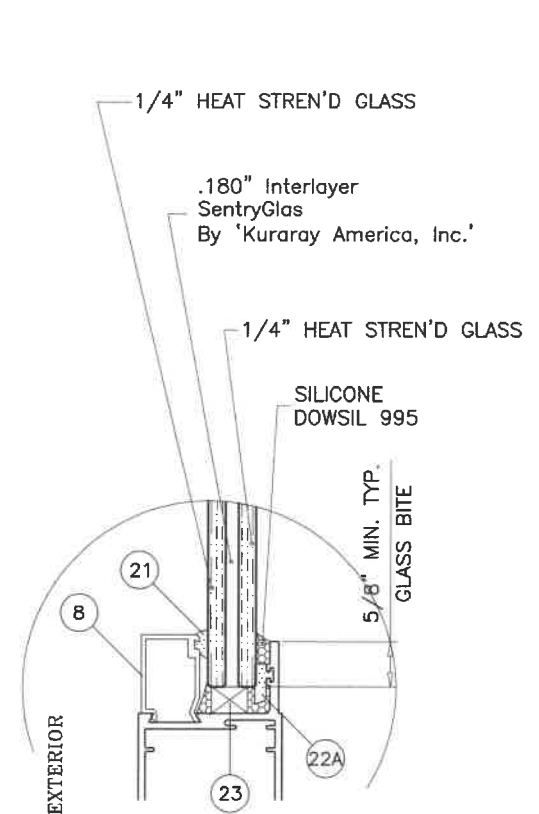

GLASS TYPE 'B'

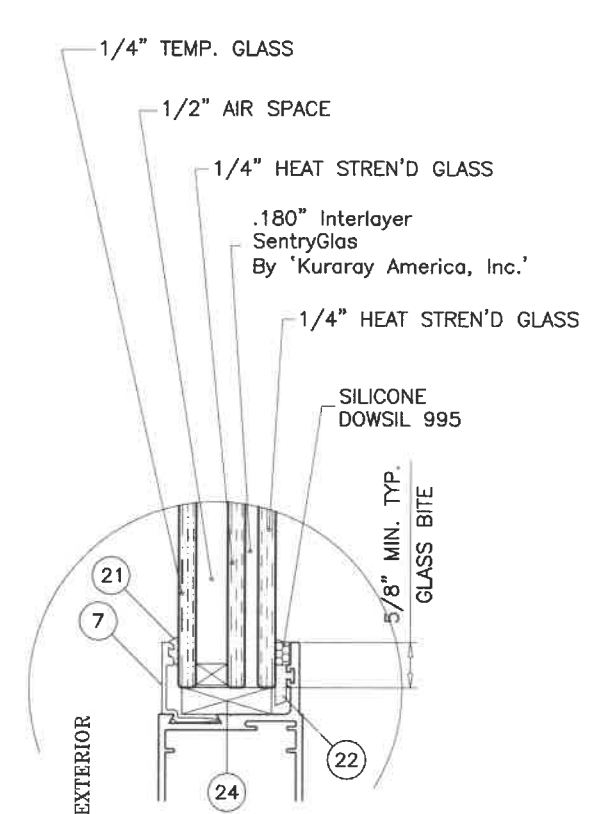

GLASS TYPE 'B1'

GLAZING DETAILS DOOR  
LEVEL 'E' IMPACT

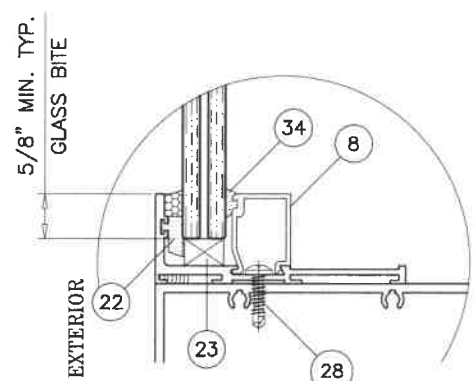

GLASS TYPE 'A'

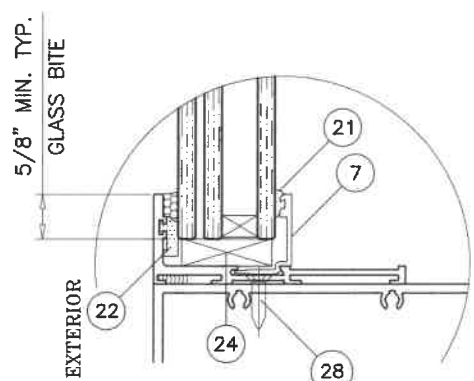

GLASS TYPE 'A1'

GLAZING DETAILS TRANSOM  
LEVEL 'D' IMPACT

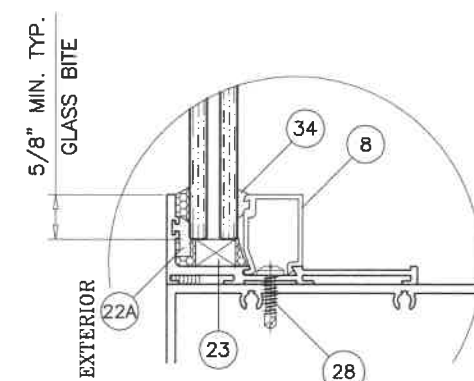

GLASS TYPE 'B'

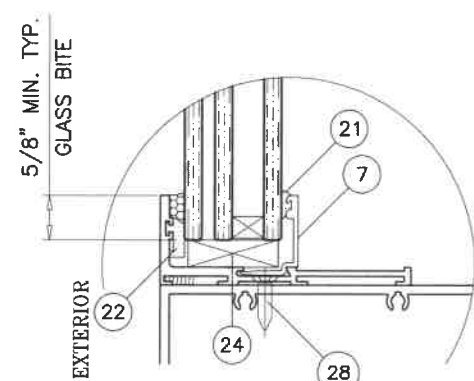

GLASS TYPE 'B1'

GLAZING DETAILS TRANSOM  
LEVEL 'E' IMPACT

1/2" AIR SPACE CONSISTING OF:  
SPACER:  
ALUMINUM BOX SPACER AROUND  
THE PERIMETER OF THE GLASS.  
PERIMETER SEALANT:  
SILICONE  
DOWSIL 791  
GE 2000

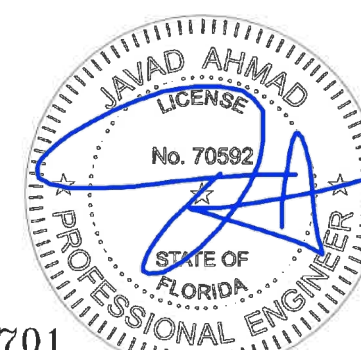

FL #20701

**af c**  
**AL-FAROOQ CORPORATION**  
ENGINEERS & PRODUCT DEVELOPMENT  
9360 SUNSET DRIVE, SUITE 220  
MIAMI, FLORIDA 33173 (C.A.N. 3538)  
TEL. (305) 264-8100 FAX. (305) 262-6978  
COMP-ANL\W17-43ENV

SERIES ENV-350 INSWING ENTRANCE DOOR (L.M.I.)  
**ENVRALUM INDUSTRIES INC.**  
5100 N.W. 72 AVENUE BLDG. C  
MIAMI, FL. 33166  
TEL. (305) 752-4411 FAX. (305) 406-3877

revisions:	no	date	by	description
date:	04-11-17	scale:	3/8" = 1"	
dr. by:	TARIQ	chk. by:		
drawing no.	W17-43			
sheet	1.1 of 10			

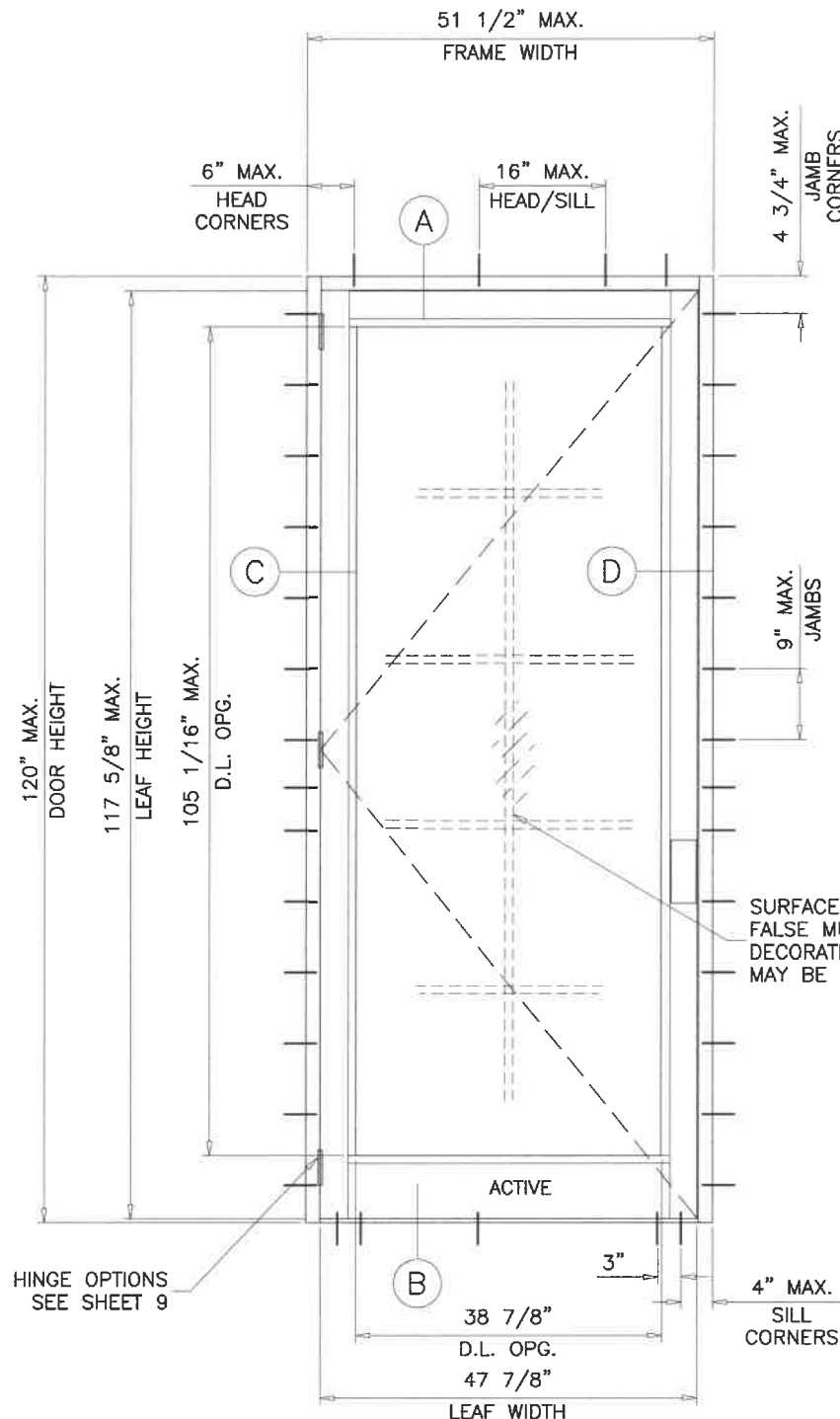

ANCHOR TYPES	NO. OF ANCHORS AT MTG. STILE ENDS	
	1/4" SHIM	3/8" SHIM
A	6	8
B	6	8
C	5	6
A1	8	-
B1	6	-
C1	6	-

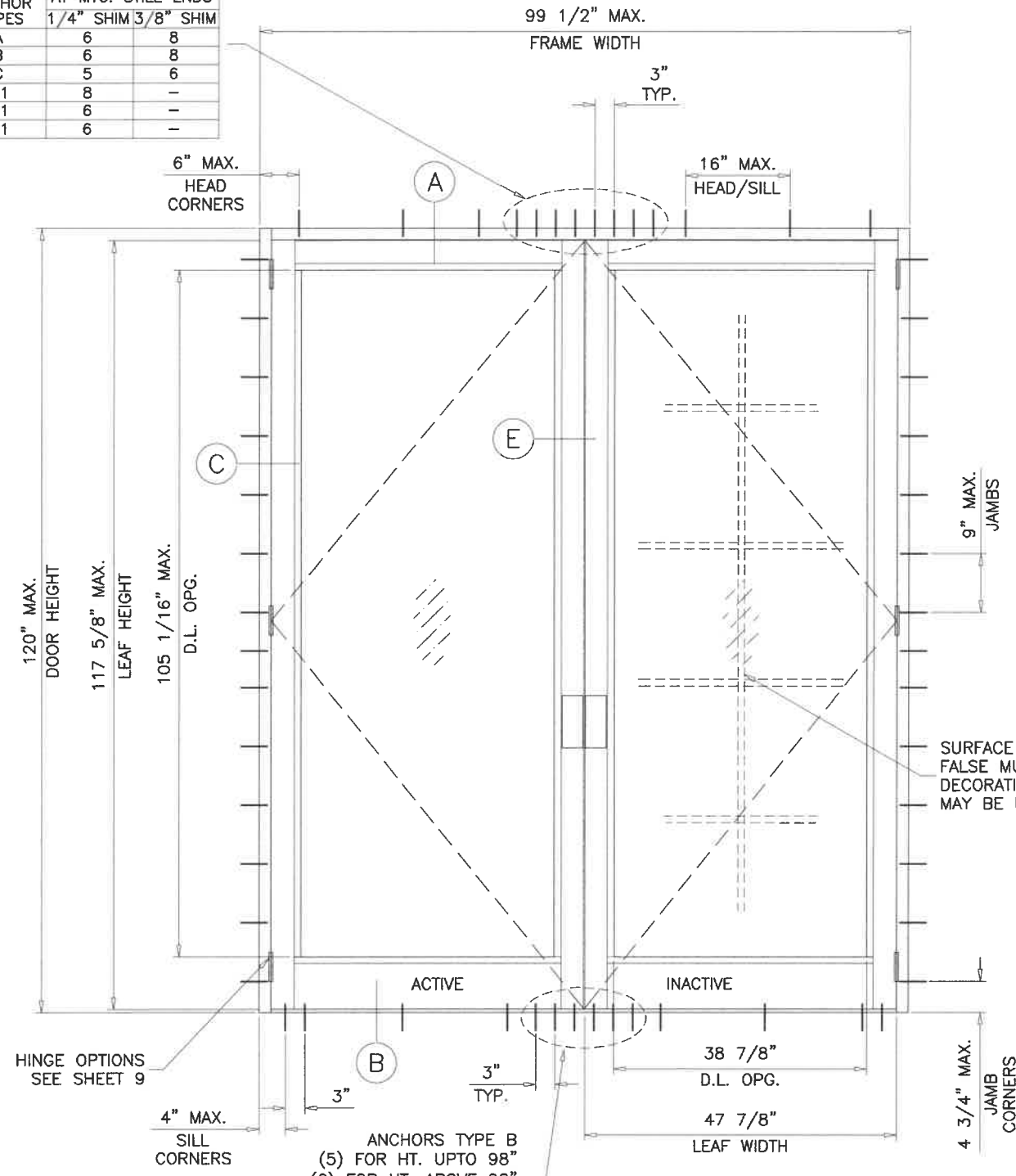

**LEVEL 'D' IMPACT**  
**DESIGN PRESSURE RATING (GLASS TYPES 'A' & 'A1')**  
**MAXIMUM DESIGN LOAD RATING = + 100.0 PSF**  
 (FOR SIZES SHOWN ABOVE OR SMALLER) - 100.0 PSF  
 SEE SHEET 4 FOR LOCK OPTIONS AND LIMITATIONS.

ANCHORS TYPE B  
 (5) FOR HT. UPTO 98"  
 (6) FOR HT. ABOVE 98"

ANCHORS TYPE B1  
 (6) FOR HT. UPTO 98"  
 (7) FOR HT. ABOVE 98"

**GLASS D.L.O. DIMS.**  
 D.L.O. HEIGHT = DOOR FRAME HEIGHT - 14.9375"  
 D.L.O. WIDTH (X DOORS) = FRAME WIDTH - 12.8125"  
 D.L.O. WIDTH (XX DOORS) = (FRAME WIDTH - 21.875")/2

NOTE:  
 GLASS CAPACITIES ON THIS SHEET ARE  
 BASED ON ASTM E1300-09 (3 SEC. GUSTS)  
 AND FLORIDA BUILDING COMMISSION  
 DECLARATORY STATEMENT DCA05-DEC-219

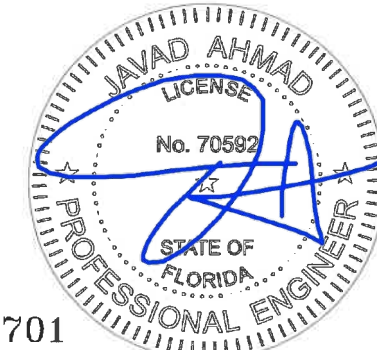

FL #20701

**af c**  
**AL-FAROOQ CORPORATION**  
 ENGINEERS & PRODUCT DEVELOPMENT  
 9360 SUNSET DRIVE, SUITE 220  
 MIAMI, FLORIDA 33173 (C.A.N. 3588)  
 TEL. (305) 264-8100 FAX. (305) 262-6978  
 COMP-ANL \W17-43ENV

SERIES ENV-350 INSWING ENTRANCE DOOR (L.M.I.)  
**ENVRALUM INDUSTRIES INC.**  
 5100 N.W. 72 AVENUE BLDG. C  
 MIAMI, FL. 33166  
 TEL. (305) 752-4411 FAX. (305) 406-3877

revisions:	no	date	description

date: 04-11-17  
 scale: 1/2"=1'-0"  
 dr. by: TARIQ  
 chk. by:

drawing no. **W17-43**  
 sheet 2 of 10

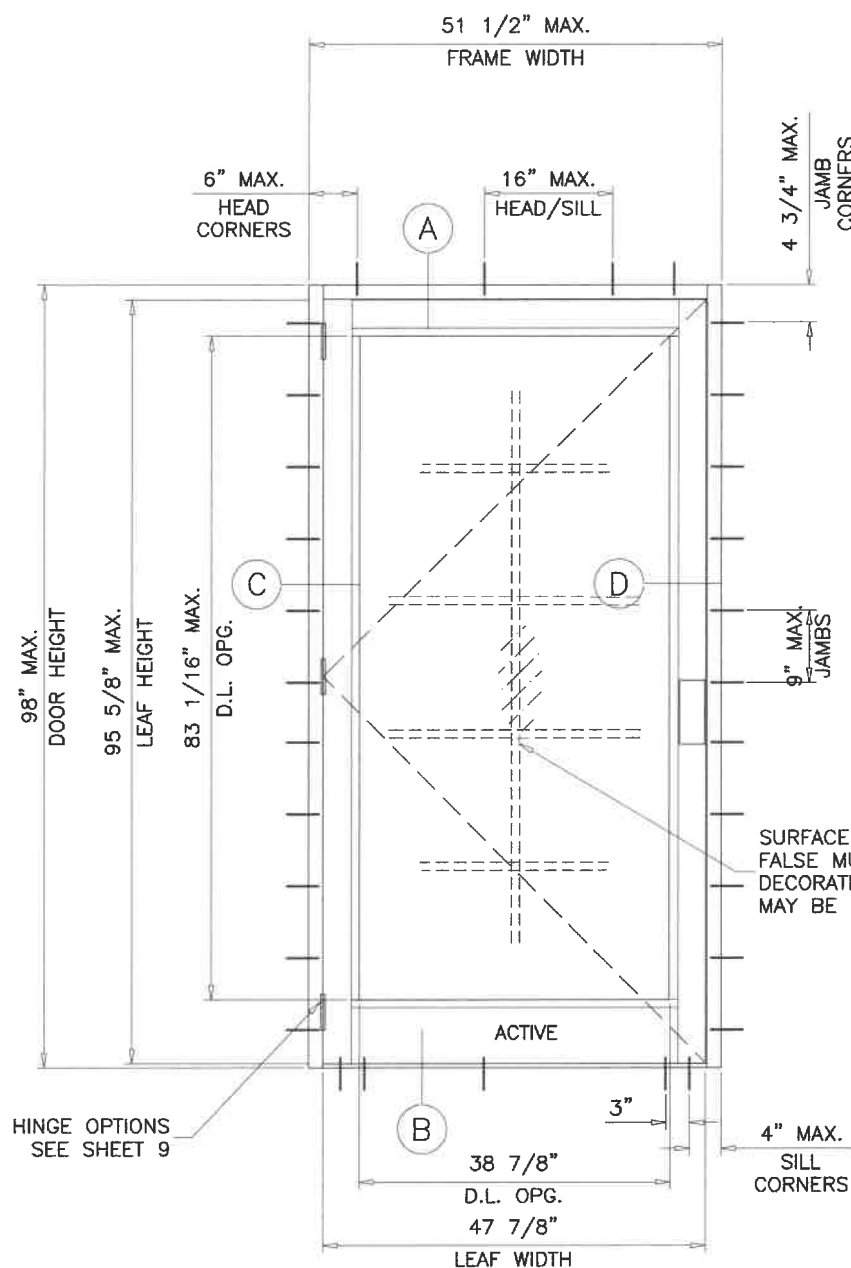

ANCHOR TYPES	NO. OF ANCHORS AT MTG. STILE ENDS	
	1/4" SHIM	3/8" SHIM
A	5	7
B	5	7
C	4	5
A1	7	-
B1	5	-
C1	5	-

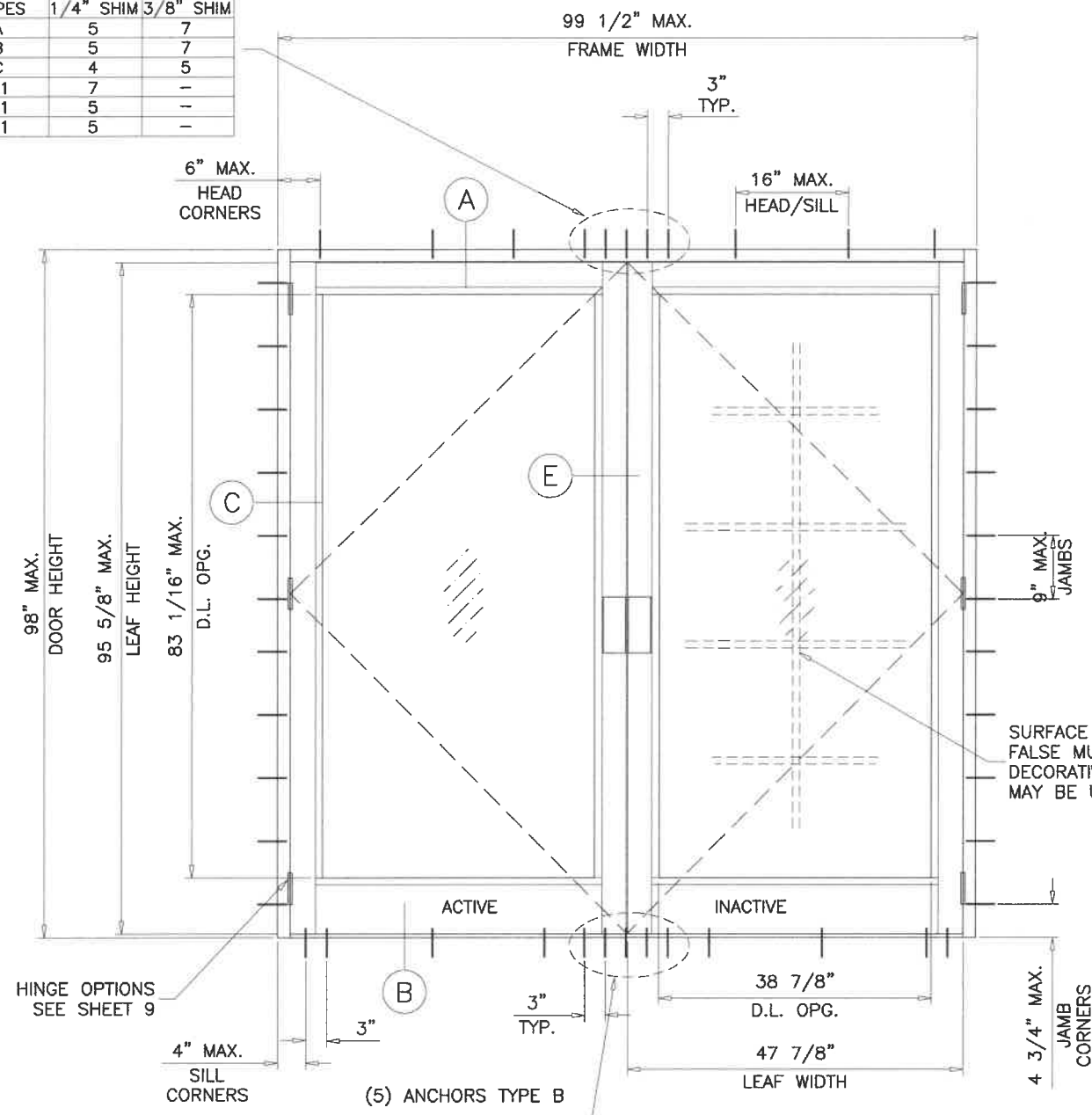

(X)

**LEVEL 'E' IMPACT**  
 DESIGN PRESSURE RATING (GLASS TYPES 'B' & 'B1')

MAXIMUM DESIGN LOAD RATING = + 100.0 PSF
(FOR SIZES SHOWN ABOVE OR SMALLER) - 100.0 PSF

SEE SHEET 4.1 FOR LOCK OPTIONS AND LIMITATIONS.

(XX)

GLASS D.L.O. DIMS.  
 D.L.O. HEIGHT = DOOR FRAME HEIGHT - 14.9375"  
 D.L.O. WIDTH (X DOORS) = FRAME WIDTH - 12.8125"  
 D.L.O. WIDTH (XX DOORS) = (FRAME WIDTH - 21.875")/2

NOTE:  
 GLASS CAPACITIES ON THIS SHEET ARE  
 BASED ON ASTM E1300-09 (3 SEC. GUSTS)  
 AND FLORIDA BUILDING COMMISSION  
 DECLARATORY STATEMENT DCA05-DEC-219

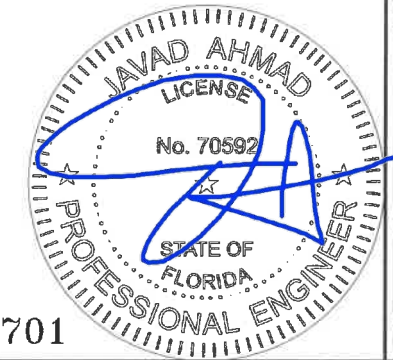

FL #20701

**AL-FAROOQ CORPORATION**  
 ENGINEERS & PRODUCT DEVELOPMENT  
 9360 SUNSET DRIVE, SUITE 220  
 MIAMI, FLORIDA 33173  
 TEL. (305) 264-8100 FAX. (305) 262-6978  
 (C.A.N. 3538)

SERIES ENV-350 INSWING ENTRANCE DOOR (L.M.I.)  
**ENVRALUM INDUSTRIES INC.**  
 5100 N.W. 72 AVENUE BLDG. C  
 MIAMI, FL. 33166  
 TEL. (305) 752-4411 FAX. (305) 406-3877

revisions:	no	date	by	description
date:	04-11-17			
scale:	1/2"=1'-0"			
dr. by:	TARIQ			
chk. by:				
drawing no.	W17-43			
sheet	2.1 of 10			

COMP-ANL \ W17-43ENV

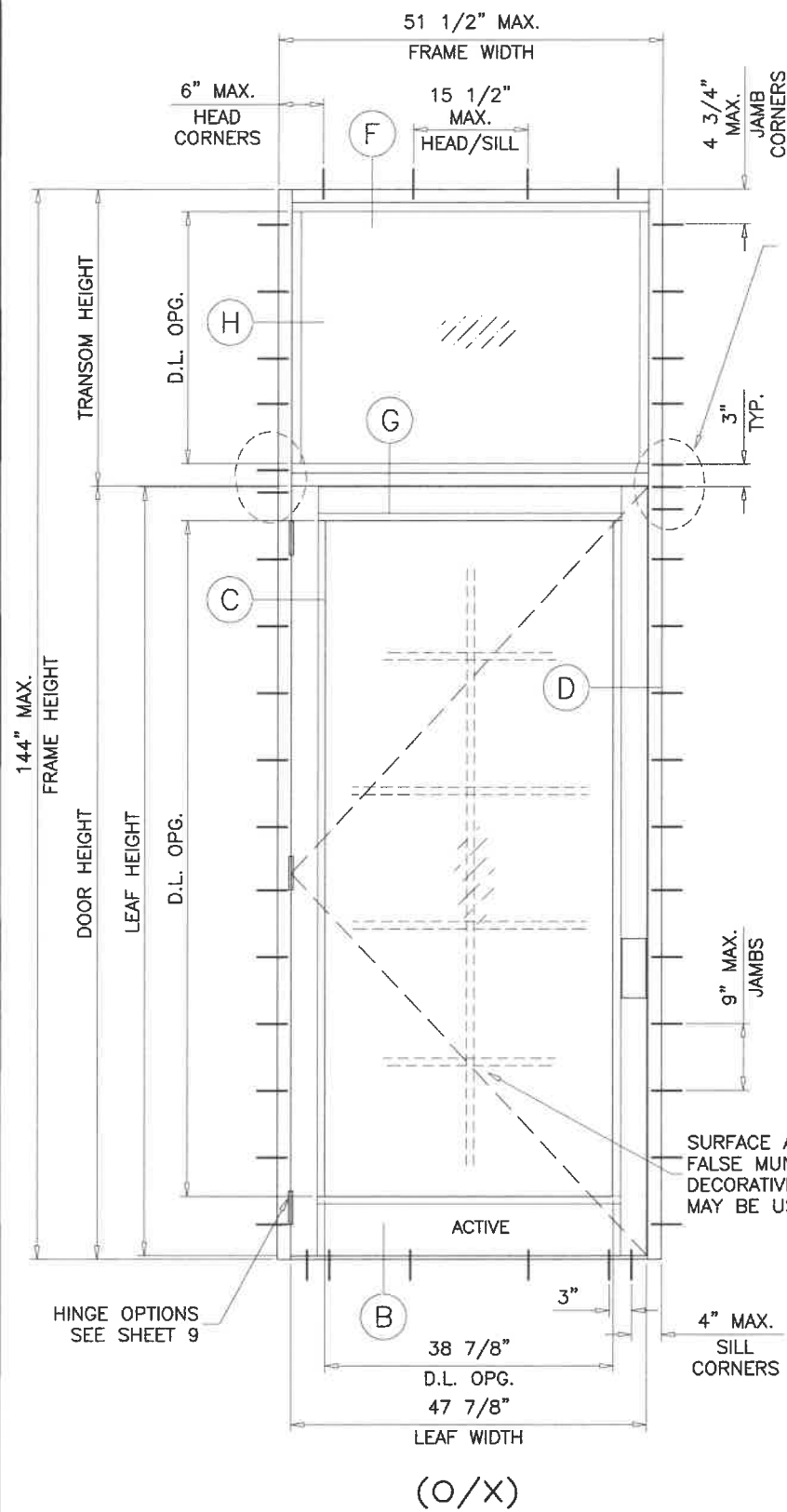

NO. OF ANCHORS AT TRANSOM ENDS

ANCHOR TYPES	1/4\" SHIM	3/8\" SHIM
A	-	2
B	-	2
BB	-	3
C	-	2
A1	2	-
B1	2	-
BB1	3	-
C1	2	-

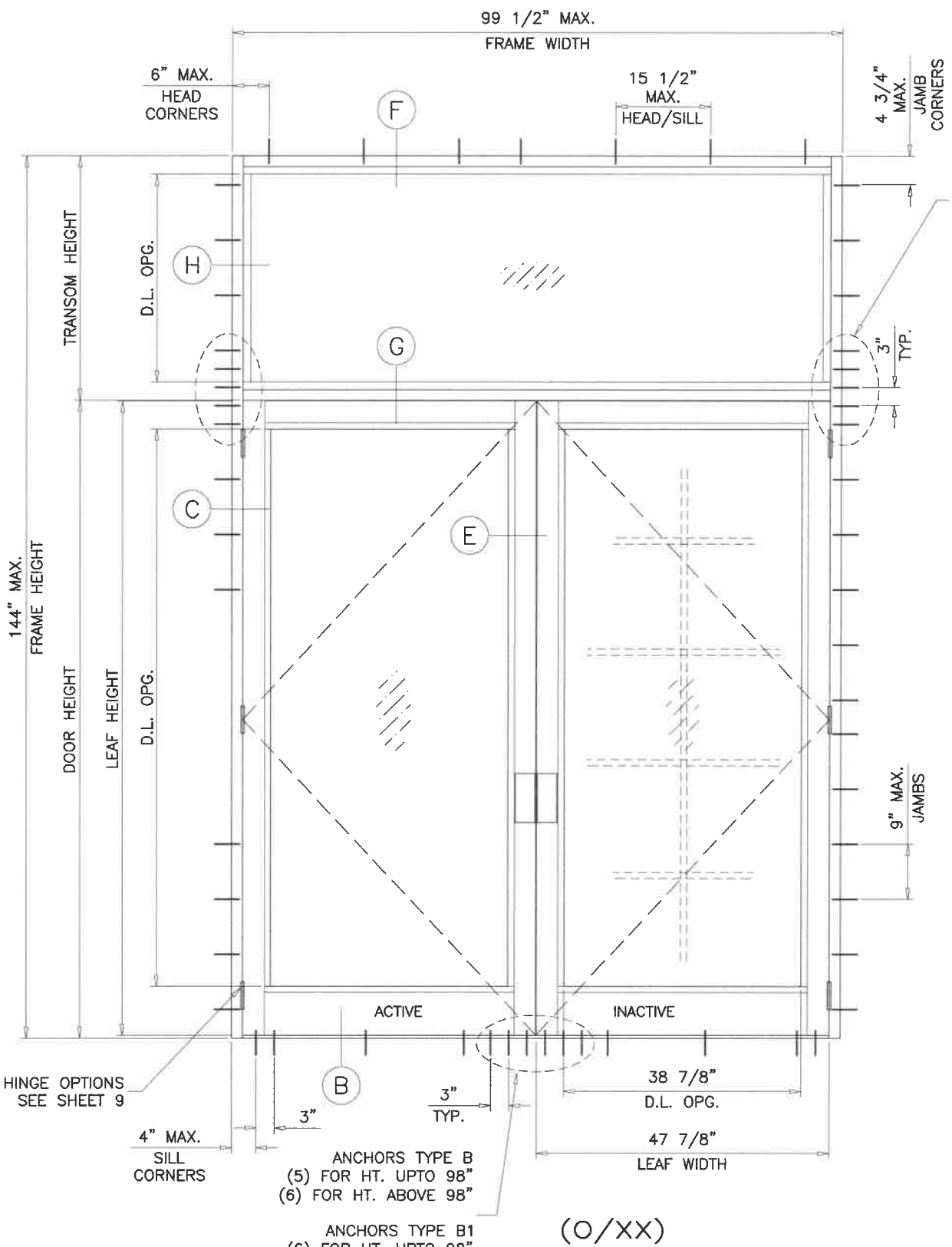

NO. OF ANCHORS AT TRANSOM ENDS

ANCHOR TYPES	1/4\" SHIM	3/8\" SHIM
A	3	4
B	3	4
BB	5	5
C	3	3
A1	5	-
B1	4	-
BB1	6	-
C1	3	-

ANCHORS TYPE B  
(5) FOR HT. UPTO 98"  
(6) FOR HT. ABOVE 98"

ANCHORS TYPE B1  
(6) FOR HT. UPTO 98"  
(7) FOR HT. ABOVE 98"

**DOORS WITH TRANSOM**

SEE SHEET 3.1 FOR TRANSOM (HORIZ. MULLION) DESIGN LOAD CAPACITY,

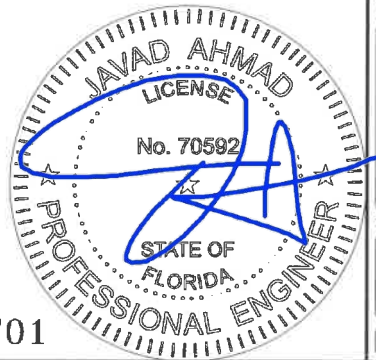

FL #20701

**afc**  
**AL-FAROOQ CORPORATION**  
 ENGINEERS & PRODUCT DEVELOPMENT  
 9360 SUNSET DRIVE, SUITE 220 (C.A.N. 3538)  
 MIAMI, FLORIDA 33173  
 TEL. (305) 264-8100 FAX. (305) 262-6978  
 COMP-ANL W17-43ENV

SERIES ENV-350 INSWING ENTRANCE DOOR (L.M.I.)  
**ENVRALUM INDUSTRIES INC.**  
 5100 N.W. 72 AVENUE BLDG. C  
 MIAMI, FL. 33166  
 TEL. (305) 752-4411 FAX. (305) 406-3877

revisions:	
no	date by description

date: 04-11-17  
 scale: 1/2"=1'-0"  
 dr. by: TARIQ  
 chk. by:   
 drawing no. **W17-43**  
 sheet 3 of 10

LEVEL 'D' & 'E' IMPACT

SINGLE OR DOUBLE DOORS WITH TRANSOM CAPACITY - PSF					
FRAME/TRANSOM WIDTH	DOOR HEIGHT	TRANSOM HEIGHT	WITHOUT REINF.	WITH REINF.	
			EXT.(+) INT.(-)	EXT.(+) INT.(-)	
37-3/4" (X)	75-1/2" (XX)	80"	24"	78.3	100.0
			30"	72.2	100.0
			36"	66.7	100.0
			42"	61.7	95.7
			48"	57.2	87.8
40-3/4" (X)	81-1/2" (XX)	80"	24"	65.7	100.0
			30"	60.3	95.1
			36"	55.4	86.4
			42"	50.9	78.6
			48"	46.9	71.4
43-3/4" (X)	87-1/2" (XX)	80"	24"	55.7	88.7
			30"	50.7	79.9
			36"	46.3	72.0
			42"	42.4	64.8
			48"	38.8	58.3
46-3/4" (X)	93-1/2" (XX)	80"	24"	47.5	75.6
			30"	43.0	67.5
			36"	39.0	60.2
			42"	35.4	53.6
			48"	31.9	48.8
49-3/4" (X)	99-1/2" (XX)	80"	24"	40.8	64.8
			30"	36.7	57.2
			36"	33.0	50.5
			42"	30.0	46.0
			48"	27.0	42.0
37-3/4" (X)	75-1/2" (XX)	84"	24"	75.4	100.0
			30"	69.7	100.0
			36"	64.4	100.0
			42"	59.7	92.7
			48"	55.4	85.1
40-3/4" (X)	81-1/2" (XX)	84"	24"	63.3	100.0
			30"	58.1	91.8
			36"	53.5	83.5
			42"	49.3	76.1
			48"	45.5	69.3
43-3/4" (X)	87-1/2" (XX)	84"	24"	53.6	85.4
			30"	49.0	77.1
			36"	44.8	69.6
			42"	41.0	62.8
			48"	37.6	56.6
46-3/4" (X)	93-1/2" (XX)	84"	24"	45.7	72.8
			30"	41.5	65.1
			36"	37.7	58.2
			42"	34.3	51.9
			48"	31.0	47.0
49-3/4" (X)	99-1/2" (XX)	84"	24"	39.3	62.4
			30"	35.4	55.2
			36"	31.9	48.8

SINGLE OR DOUBLE DOORS WITH TRANSOM CAPACITY - PSF					
FRAME/TRANSOM WIDTH	DOOR HEIGHT	TRANSOM HEIGHT	WITHOUT REINF.	WITH REINF.	
			EXT.(+) INT.(-)	EXT.(+) INT.(-)	
37-3/4" (X)	75-1/2" (XX)	90"	24"	71.5	100.0
			30"	66.2	100.0
			36"	61.4	96.2
			42"	57.0	88.5
			48"	53.0	81.4
40-3/4" (X)	81-1/2" (XX)	90"	24"	60.0	95.6
			30"	55.2	87.2
			36"	51.0	79.6
			42"	47.1	72.6
			48"	43.5	66.3
43-3/4" (X)	87-1/2" (XX)	90"	24"	50.8	80.9
			30"	46.5	73.2
			36"	42.7	66.3
			42"	39.2	59.9
			48"	35.9	53.4
46-3/4" (X)	93-1/2" (XX)	90"	24"	43.3	69.0
			30"	39.5	61.9
			36"	35.9	55.4
49-3/4" (X)	99-1/2" (XX)	90"	24"	37.2	59.1
			30"	33.6	52.5
			36"	30.0	46.0
37-3/4" (X)	75-1/2" (XX)	96"	24"	67.9	100.0
			30"	63.0	99.7
			36"	58.6	91.8
			42"	54.5	84.6
			48"	50.8	78.0
40-3/4" (X)	81-1/2" (XX)	96"	24"	57.0	90.9
			30"	52.6	83.1
			36"	48.7	75.9
			42"	45.0	69.5
			48"	41.7	63.5
43-3/4" (X)	87-1/2" (XX)	96"	24"	48.2	76.9
			30"	44.3	69.7
			36"	40.7	63.2
			42"	37.6	58.9
			48"	34.5	54.0
46-3/4" (X)	93-1/2" (XX)	96"	24"	41.2	65.5
			30"	37.6	58.9
			36"	34.0	52.0
49-3/4" (X)	99-1/2" (XX)	96"	24"	35.4	56.1
			30"	31.9	50.0
			36"	28.4	44.0

SINGLE OR DOUBLE DOORS WITH TRANSOM CAPACITY - PSF					
FRAME/TRANSOM WIDTH	DOOR HEIGHT	TRANSOM HEIGHT	WITHOUT REINF.	WITH REINF.	
			EXT.(+) INT.(-)	EXT.(+) INT.(-)	
37-3/4" (X)	75-1/2" (XX)	102"	24"	64.7	100.0
			30"	60.2	95.1
			36"	56.0	87.8
			42"	52.3	81.1
			48"	48.6	74.4
40-3/4" (X)	81-1/2" (XX)	102"	24"	54.2	86.5
			30"	50.2	79.8
			36"	46.5	72.6
			42"	43.2	66.6
			48"	40.0	60.0
43-3/4" (X)	87-1/2" (XX)	102"	24"	45.9	73.2
			30"	42.3	66.6
			36"	38.7	60.0
46-3/4" (X)	93-1/2" (XX)	102"	24"	39.2	62.4
			30"	35.6	55.8
			36"	32.0	49.2
37-3/4" (X)	75-1/2" (XX)	108"	24"	61.7	98.5
			30"	57.5	91.0
			36"	53.7	84.1
			42"	50.0	77.2
			48"	46.3	70.3
40-3/4" (X)	81-1/2" (XX)	108"	24"	51.8	82.6
			30"	48.0	75.8
			36"	44.6	69.6
43-3/4" (X)	87-1/2" (XX)	108"	24"	43.9	69.9
			30"	40.3	63.0
			36"	36.7	56.0

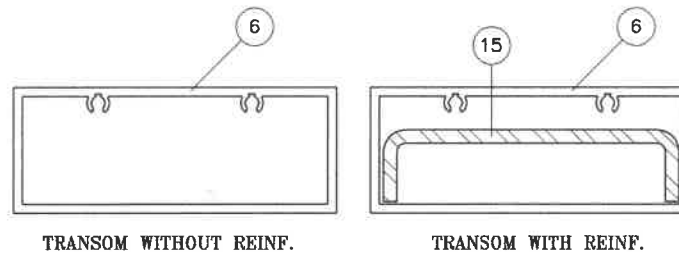

NOTE:  
GLASS CAPACITIES ON THIS SHEET ARE  
BASED ON ASTM E1300-09 (3 SEC. GUSTS)  
AND FLORIDA BUILDING COMMISSION  
DECLARATORY STATEMENT DCA05-DEC-219

FL #20701

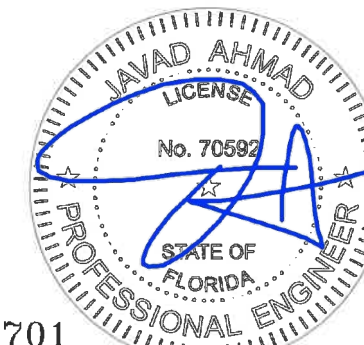



**AL-FAROOQ CORPORATION**  
ENGINEERS & PRODUCT DEVELOPMENT  
9360 SUNSET DRIVE, SUITE 220 (C.A.N. 3588)  
MIAMI, FLORIDA 33173 TEL. (305) 262-6978  
FAX. (305) 264-8100

---

SERIES ENV-350 INSWING ENTRANCE DOOR (L.M.I.)

**ENVRALUM INDUSTRIES INC.**  
5100 N.W. 72 AVENUE BLDG. C  
MIAMI, FL. 33166  
TEL. (305) 752-4411 FAX. (305) 406-3877

---

revisions:	no	date	by	description

---

date: 04-11-17  
scale: 1/2"=1'-0"  
dr. by: TARIQ  
chk. by:  

---

drawing no.  
**W17-43**  
sheet 3.1 of 10

**LOCK OPTIONS: LEVEL 'D' IMPACT**

STD. 3 POINT LOCK (LEVEL 'D' IMPACT ONLY)  
 MAX. FRAME HEIGHT = 120 IN.  
 MAX. LEAF WIDTH = 48 IN.  
 MAX. DESIGN LOAD = 100 PSF

**ACTIVE LEAF:**

3 POINT LOCK SYSTEM BY 'INTERLOCK' AT 39" FROM BOTTOM  
 HANDLE ACTIVATES DEAD BOLT AND SHOOT BOLTS ENGAGING AT HEAD AND SILL  
 KEY OPERATED ON EXTERIOR AND THUMB TURN ON INTERIOR  
 FASTENED TO ACTIVE LEAF LOCK STILE WITH  
 (2) #8-32 X 2" OH MS

**INACTIVE LEAF:**

2 POINT LOCK SYSTEM BY 'INTERLOCK' AT 39" FROM BOTTOM  
 HANDLE ACTIVATES SHOOT BOLTS ENGAGING AT HEAD AND SILL  
 FASTENED TO INACTIVE LEAF LOCK STILE WITH  
 (2) #8-32 X 2" OH MS

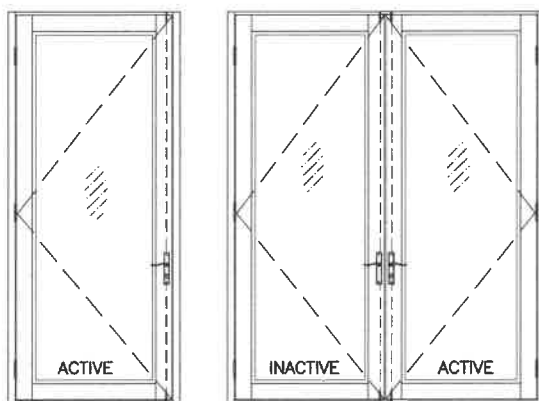

STD. 3 POINT LOCK (LEVEL 'D' IMPACT ONLY)  
 MAX. FRAME HEIGHT = 120 IN.  
 MAX. LEAF WIDTH = 48 IN.  
 MAX. DESIGN LOAD = 100 PSF

**ACTIVE LEAF:**

THREE POINT LOCK SYSTEM SERIES 2222 BY 'REGENT HARDWARE'  
 KEY OPERATED FROM EXTERIOR AND THUMB TURN ON INTERIOR WITH CONCEALED FLUSH BOLTS AT TOP & BOTTOM OF LOCK STILE  
 LOCATED AT 34" FROM BOTTOM OF LEAF

**INACTIVE LEAF:**

MANUALLY OPERATED TWO POINT LOCK SYSTEM BY 'REGENT HARDWARE' WITH CONCEALED FLUSH BOLTS AT TOP & BOTTOM OF LOCK STILE  
 FASTENED WITH  
 (2) #8-32 X 1/4" PH MACHINE SCREWS

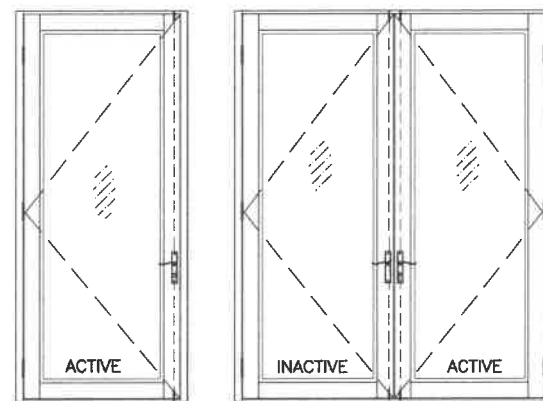

STD. 3 POINT LOCK (LEVEL 'D' IMPACT ONLY)  
 MAX. FRAME HEIGHT = 120 IN.  
 MAX. LEAF WIDTH = 48 IN.  
 MAX. DESIGN LOAD = 100 PSF

**ACTIVE LEAF:**

KEY OPERATED THREE POINT LOCK SYSTEM BY 'ADAMS RITE' WITH CONCEALED FLUSH BOLTS AT TOP & BOTTOM OF LOCK STILE AND A THUMB TURN ON THE INTERIOR, LOCATED AT 40" FROM BOTTOM OF PANEL  
 FASTENED WITH  
 (2) #12-24 X 1/2" FH MACHINE SCREWS

**INACTIVE LEAF:**

MANUALLY OPERATED TWO POINT LOCK SYSTEM BY 'ADAMS RITE' WITH CONCEALED FLUSH BOLTS AT TOP & BOTTOM OF LOCK STILE  
 FASTENED WITH  
 (2) #8-32 X 1/4" PH MACHINE SCREWS

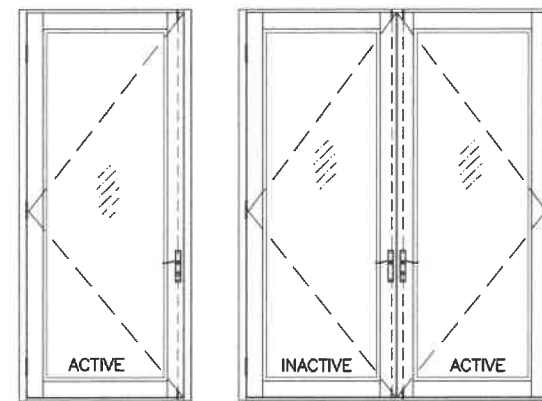

FRAME HEIGHTS DOES INCLUDE OPTIONAL TRANSOM

MULTI-POINT LOCK (LEVEL 'D' IMPACT ONLY)  
 MAX. FRAME HEIGHT = 109-3/4 IN.  
 MAX. LEAF WIDTH = 48 IN.  
 MAX. DESIGN LOAD = 100 PSF

**ACTIVE & INACTIVE LEAF:**

MULTI POINT LOCK SYSTEM '7000 SERIES' BY 'SARGENT'  
 LEVER TYPE HANDLE WITH KEY CYLINDER ON EXTERIOR AND INTERIOR, LOCATED AT 40" FROM BOTTOM, ACTIVATES CONCEALED FLUSH BOLTS ENGAGING AT HEAD AND SILL

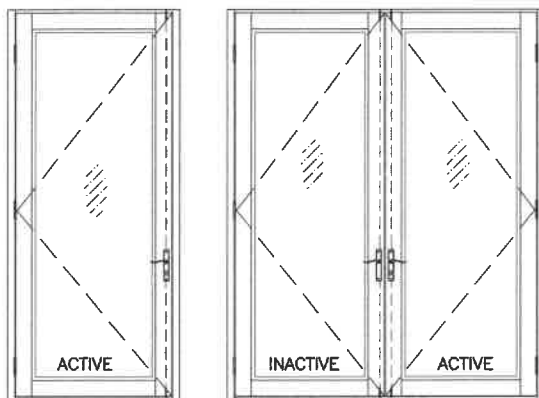

**af c**  
**AL-FAROOQ CORPORATION**  
 ENGINEERS & PRODUCT DEVELOPMENT  
 9360 SUNSET DRIVE, SUITE 220 (C.A.N. 3538)  
 MIAMI, FLORIDA 33173 FAX. (305) 262-6978  
 TEL. (305) 264-8100

SERIES ENV-350 INSWING ENTRANCE DOOR (L.M.I.)  
**ENVRALUM INDUSTRIES INC.**  
 5100 N.W. 72 AVENUE BLDG. C  
 MIAMI, FL. 33166  
 TEL. (305) 752-4411 FAX. (305) 406-3877

revisions:	no	date	by	description

date: 04-11-17  
 scale: 3/8" = 1"  
 dr. by: TARIQ  
 chk. by:

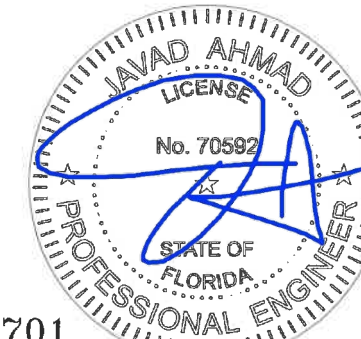

drawing no.  
**W17-43**  
 sheet 4 of 10

FL #20701

**LOCK OPTIONS: LEVEL 'D' IMPACT**

PANIC EXIT DEVICE (LEVEL 'D' IMPACT ONLY)  
 MAX. FRAME HEIGHT = 98 IN.  
 MAX. LEAF WIDTH = 48 IN.  
 MAX. DESIGN LOAD = 75 PSF

**ACTIVE & INACTIVE LEAF:**

CONCEALED VERTICAL ROD PANIC EXIT DEVICE # 5770 BY 'REGENT HARDWARE' LOCATED AT 40" FROM SILL AT EACH LEAF.  
 FASTENED WITH  
 (1) #10 X 3/8" FH SELF DRILLING SCREW AT ONE END AND  
 (2) #10 X 1/2" FH SELF DRILLING SCREWS AT OTHER END

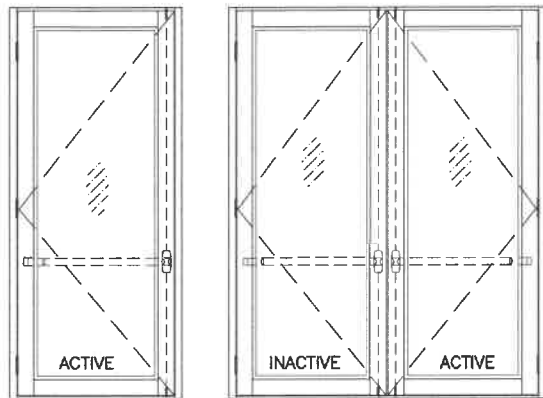

PANIC EXIT DEVICE (LEVEL 'D' IMPACT ONLY)  
 MAX. FRAME HEIGHT = 120 IN.  
 MAX. LEAF WIDTH = 48 IN.  
 MAX. DESIGN LOAD = 100 PSF

**ACTIVE & INACTIVE LEAF:**

CONCEALED VERTICAL ROD PANIC EXIT DEVICE # G86 OR EX76 BY 'ADAMS RITE' LOCATED AT 40" FROM SILL AT EACH LEAF.  
 FASTENED WITH  
 (2) #10-32 X 3/4" FH MACHINE SCREWS AT ONE END AND  
 (2) #10-24 X 1/2" FH MACHINE SCREWS AT OTHER END

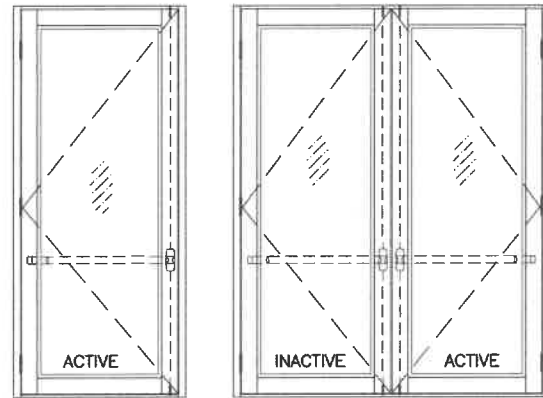

PANIC EXIT DEVICE (LEVEL 'D' IMPACT ONLY)  
 MAX. FRAME HEIGHT = 120 IN.  
 MAX. LEAF WIDTH = 48 IN.  
 MAX. DESIGN LOAD = 100 PSF

**ACTIVE & INACTIVE LEAF:**

CONCEALED VERTICAL ROD PANIC EXIT DEVICE PRECISION 2800 BY 'STANLEY' LOCATED AT 40" FROM SILL AT EACH LEAF.  
 FASTENED WITH  
 (2) #10-32 X 3/4" FH MACHINE SCREWS AT ONE END AND  
 (2) #10-24 X 1/2" FH MACHINE SCREWS AT OTHER END

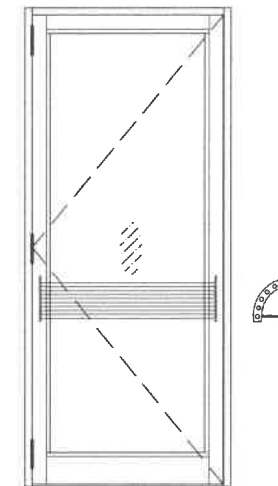
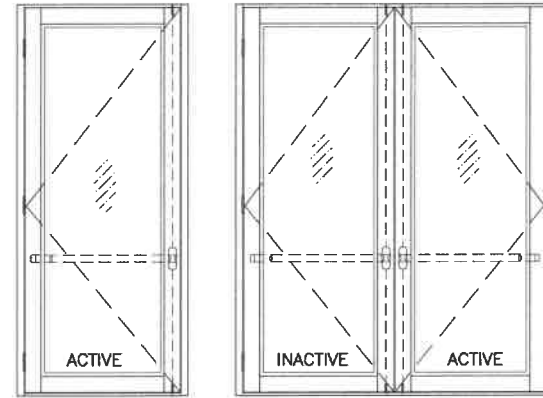

**PANIC DEVICE GUARD**

(5) 1" DIA. ROUND ALUM BARS  
 SPACED 1" APART  
 SCREWED TO A 3/8" THICK FLAT BAR  
 FASTENED TO DOOR LEAF WITH  
 (4) 1/4-20 X 3/4" SMS

GUARD TO BE INSTALLED OVER PANIC DEVICE DURING PERIODS OF HURRICANE WARNING.

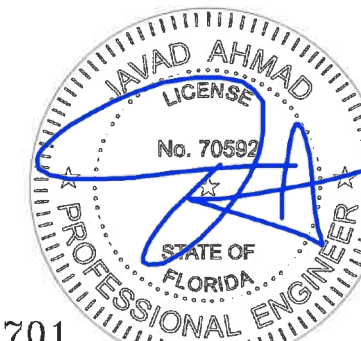

FL #20701

**af c**  
**AL-FAROOQ CORPORATION**  
 ENGINEERS & PRODUCT DEVELOPMENT  
 9360 SUNSET DRIVE, SUITE 220 (C.A.N. 3538)  
 MIAMI, FLORIDA 33173 TEL. (305) 262-6978  
 TEL. (305) 264-8100 FAX. (305) 262-6978  
 COMP-ANL \ W17-43ENV

SERIES ENV-350 INSWING ENTRANCE DOOR (L.M.I.)  
**ENVIRALUM INDUSTRIES INC.**  
 5100 N.W. 72 AVENUE BLDG. C  
 MIAMI, FL. 33166  
 TEL. (305) 752-4411 FAX. (305) 406-3877

no	date	by	description

date: 04-11-17  
 scale: 3/8" = 1"  
 dr. by: TARIQ  
 chk. by:   
 drawing no. **W17-43**  
 sheet 4.1 of 10



**LOCK OPTIONS: LEVEL 'E' IMPACT**

STD. 3 POINT LOCK (LEVEL 'E' IMPACT)  
 MAX. FRAME HEIGHT = 98 IN.  
 MAX. LEAF WIDTH = 48 IN.  
 MAX. DESIGN LOAD = 100 PSF

ACTIVE LEAF:

THREE POINT LOCK SYSTEM SERIES 2222 BY 'REGENT HARDWARE'  
 KEY OPERATED FROM EXTERIOR AND THUMB TURN ON INTERIOR WITH CONCEALED FLUSH BOLTS AT TOP & BOTTOM OF LOCK STILE LOCATED AT 40" FROM BOTTOM OF LEAF

INACTIVE LEAF:

MANUALLY OPERATED TWO POINT LOCK SYSTEM BY 'REGENT HARDWARE' WITH CONCEALED FLUSH BOLTS AT TOP & BOTTOM OF LOCK STILE FASTENED WITH  
 (2) #8-32 X 1/4" PH MACHINE SCREWS

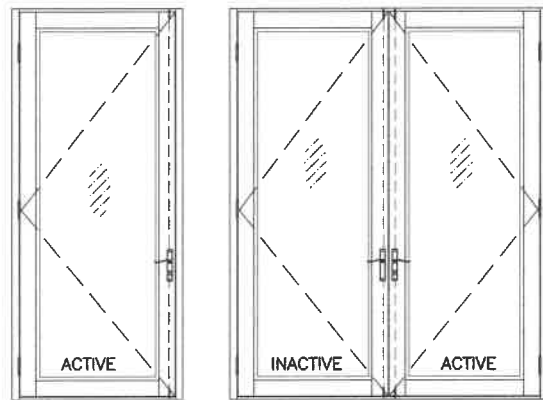

STD. 3 POINT LOCK (LEVEL 'E' IMPACT)  
 MAX. FRAME HEIGHT = 98 IN.  
 MAX. LEAF WIDTH = 48 IN.  
 MAX. DESIGN LOAD = 100 PSF

ACTIVE LEAF:

KEY OPERATED THREE POINT LOCK SYSTEM BY 'ADAMS RITE' WITH CONCEALED FLUSH BOLTS AT TOP & BOTTOM OF LOCK STILE AND A THUMB TURN ON THE INTERIOR, LOCATED AT 40" FROM BOTTOM OF PANEL FASTENED WITH  
 (2) #12-24 X 1/2" FH MACHINE SCREWS

INACTIVE LEAF:

MANUALLY OPERATED TWO POINT LOCK SYSTEM BY 'ADAMS RITE' WITH CONCEALED FLUSH BOLTS AT TOP & BOTTOM OF LOCK STILE FASTENED WITH  
 (2) #8-32 X 1/4" PH MACHINE SCREWS

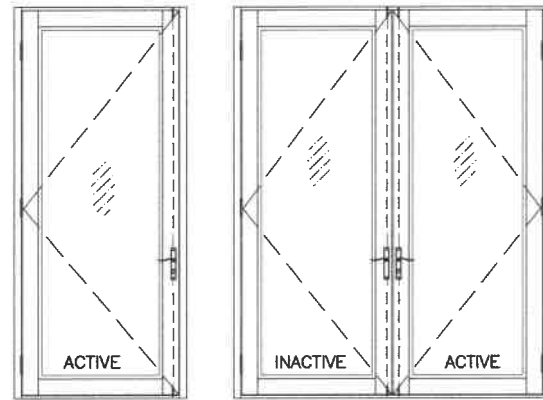

MULTI-POINT LOCK (LEVEL 'E' IMPACT)  
 MAX. FRAME HEIGHT = 98 IN.  
 MAX. LEAF WIDTH = 48 IN.  
 MAX. DESIGN LOAD = 100 PSF

ACTIVE & INACTIVE LEAF:

MULTI POINT LOCK SYSTEM '7000 SERIES' BY 'SARGENT'  
 LEVER TYPE HANDLE WITH KEY CYLINDER ON EXTERIOR AND INTERIOR, LOCATED AT 40" FROM BOTTOM, ACTIVATES CONCEALED FLUSH BOLTS ENGAGING AT HEAD AND SILL

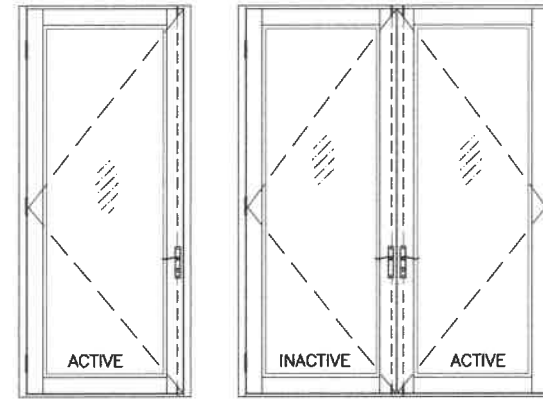

PANIC EXIT DEVICE (LEVEL 'E' IMPACT)  
 MAX. FRAME HEIGHT = 98 IN.  
 MAX. LEAF WIDTH = 48 IN.  
 MAX. DESIGN LOAD = 100 PSF

ACTIVE & INACTIVE LEAF:

CONCEALED VERTICAL ROD PANIC EXIT DEVICE PRECISION 2800 BY 'STANLEY' LOCATED AT 40" FROM SILL AT EACH LEAF. FASTENED WITH  
 (2) #10-32 X 3/4" FH MACHINE SCREWS AT ONE END AND  
 (2) #10-24 X 1/2" FH MACHINE SCREWS AT OTHER END

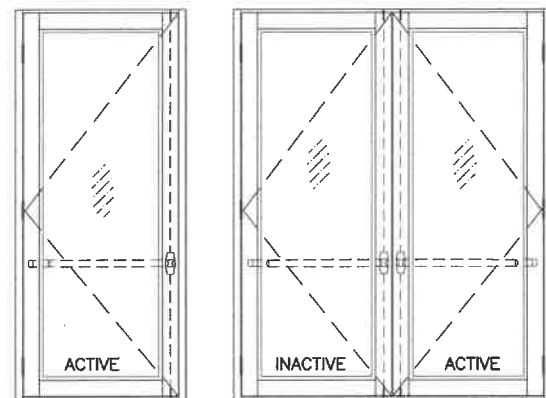

**AL-FAROOQ CORPORATION**  
 ENGINEERS & PRODUCT DEVELOPMENT  
 9360 SUNSET DRIVE, SUITE 220  
 MIAMI, FLORIDA 33173 (C.A.N. 3538)  
 TEL. (305) 264-8100 FAX. (305) 262-6978

SERIES ENV-350 INSWING ENTRANCE DOOR (L.M.I.)  
**ENVRALUM INDUSTRIES INC.**  
 5100 N.W. 72 AVENUE BLDG. C  
 MIAMI, FL. 33166  
 TEL. (305) 752-4411 FAX. (305) 406-3877

no	date	description

date: 04-11-17  
 scale: 3/8" = 1"  
 dr. by: TARIQ  
 chk. by:

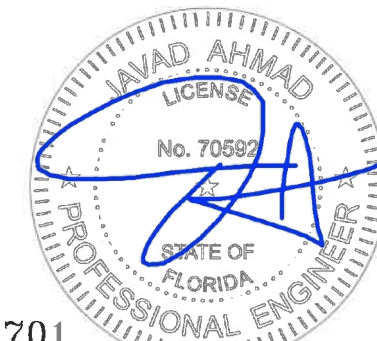

drawing no.  
**W17-43**  
 sheet 4.2 of 10

FL #20701

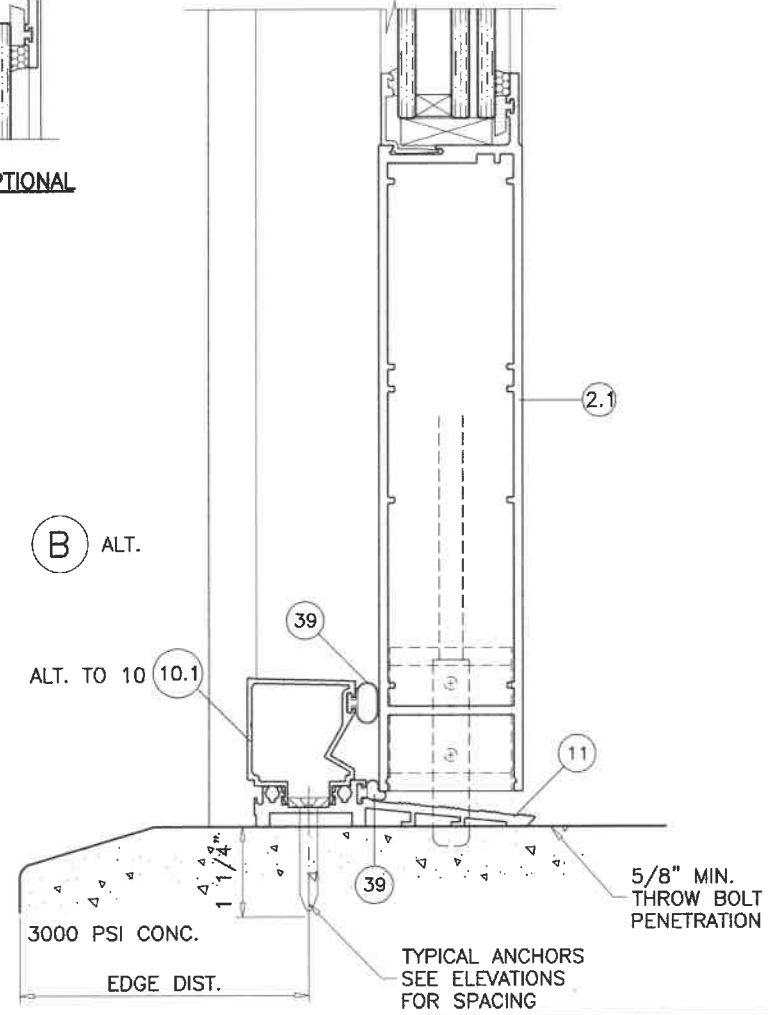
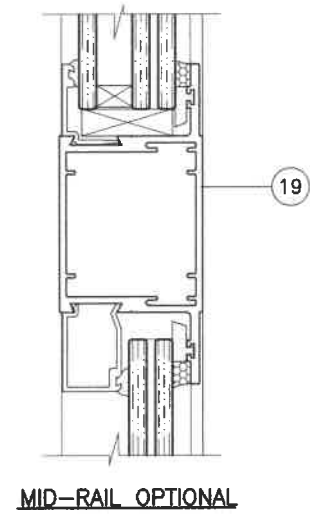
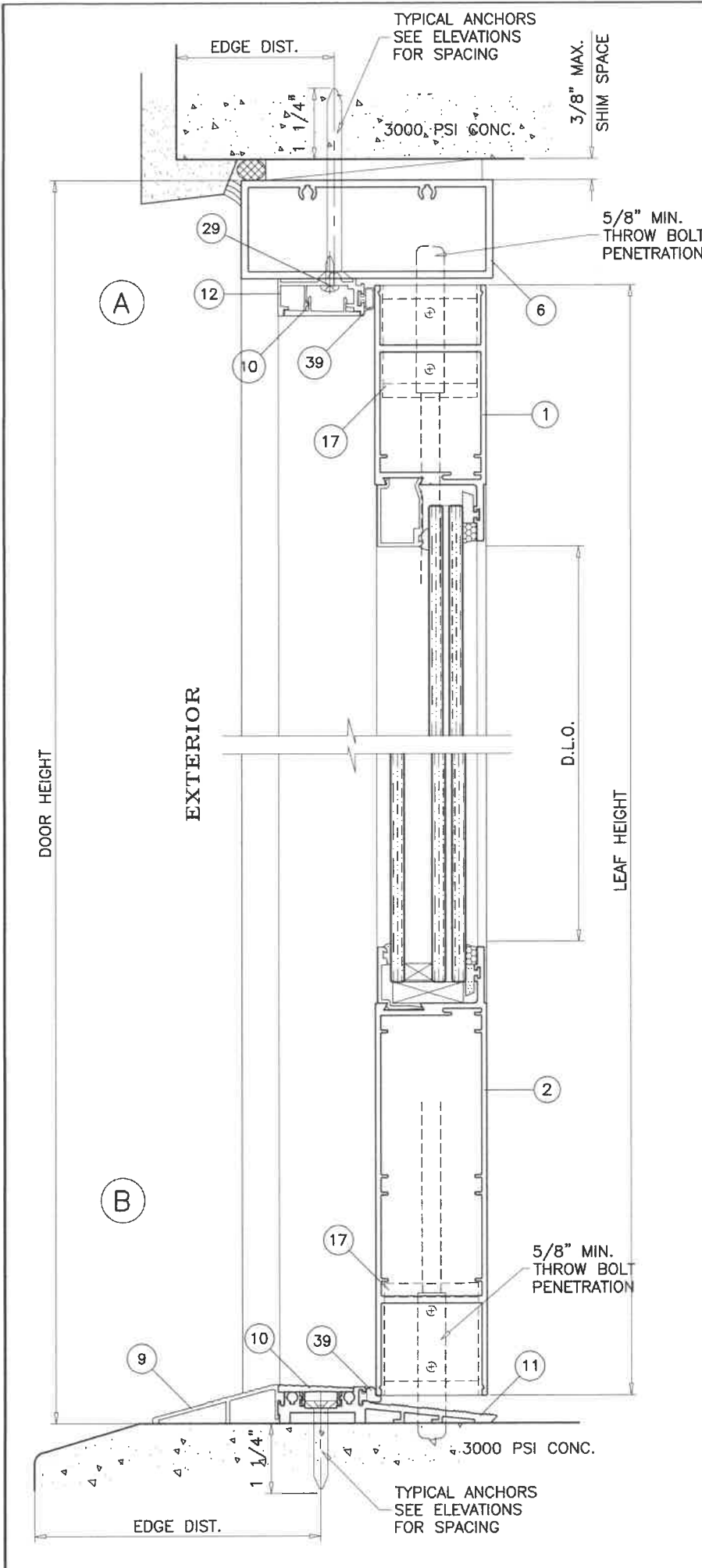

FL #20701

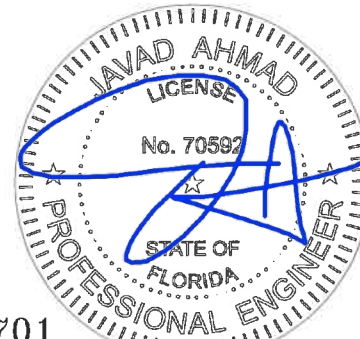

**AL-FAROOQ CORPORATION**  
 ENGINEERS & PRODUCT DEVELOPMENT  
 9360 SUNSET DRIVE, SUITE 220  
 MIAMI, FLORIDA 33173 (C.A.N. 3538)  
 TEL. (305) 264-8100 FAX. (305) 262-6978

SERIES ENV-350 INSWING ENTRANCE DOOR (L.M.I.)  
**ENVIRALUM INDUSTRIES INC.**  
 5100 N.W. 72 AVENUE BLDG. C  
 MIAMI, FL. 33166  
 TEL. (305) 752-4411 FAX. (305) 406-3877

revisions:	no	date	by	description

date: 04-11-17  
 scale: 3/8" = 1"  
 dr. by: TARIQ  
 chk. by:

drawing no.  
**W17-43**  
 sheet 5 of 10

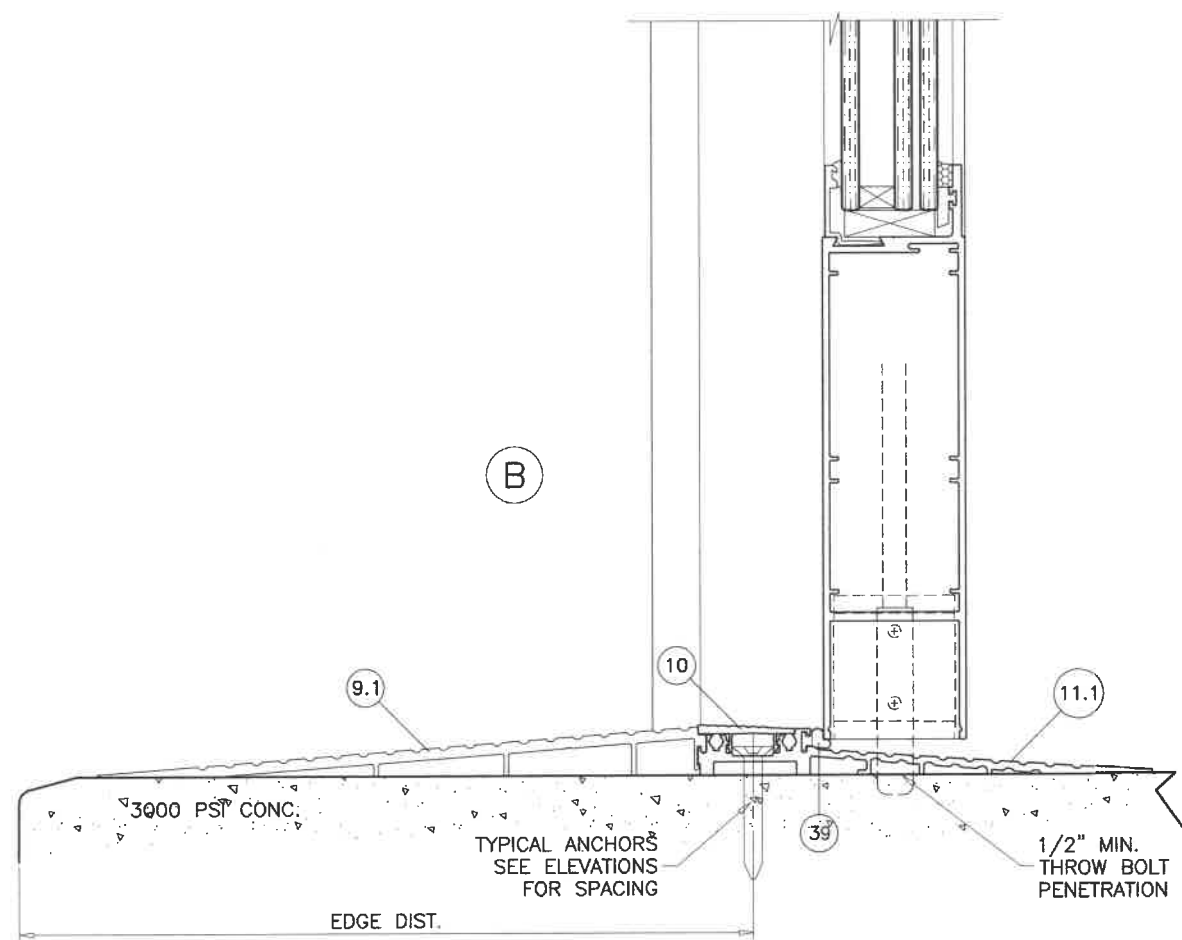

ADA COMPLIANT THRESHOLD

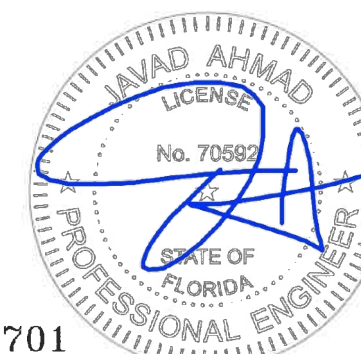

FL #20701

Sealed 5/10/19

SERIES ENV-350 INSWING ENTRANCE DOOR (L.M.I.)  
**ENVIRALUM INDUSTRIES INC.**  
 5100 N.W. 72 AVENUE BLDG. C  
 MIAMI, FL. 33166  
 TEL. (305) 752-4411 FAX. (305) 406-3877

**AL-FAROOQ CORPORATION**  
 ENGINEERS & PRODUCT DEVELOPMENT  
 9360 SUNSET DRIVE, SUITE 220  
 MIAMI, FLORIDA 33173 (C.A.N. 3538)  
 TEL. (305) 264-8100 FAX. (305) 262-6978

revisions:

no	date	by	description

date: 04-11-17  
 scale: 3/8" = 1"  
 dr. by: TARIQ  
 chk. by:

drawing no.  
**W17-43**  
 sheet 5.1 of 10

COMP-ANL\W17-43ENV

WOOD BUCKS AND METAL STRUCTURE NOT BY ENVIRALUM MUST SUSTAIN LOADS IMPOSED BY GLAZING SYSTEM AND TRANSFER THEM TO THE BUILDING STRUCTURE.

TYPICAL ANCHORS: SEE ELEV. FOR SPACING

TYPE 'A'- 5/16" DIA ULTRACON BY 'ELCO' (Fu=177 KSI, Fy=155 KSI)  
 INTO WOOD STRUCTURES  
 2" MIN. PENETRATION INTO WOOD (HEAD/SILL/JAMBS)  
 THRU 1BY OR 2BY BUCKS INTO CONC. OR MASONRY  
 1-3/4" MIN. EMBED INTO CONCRETE (HEAD/SILL/JAMBS)  
 1-3/4" MIN. EMBED INTO FILLED BLOCKS (JAMBS)  
 DIRECTLY INTO MASONRY  
 1-3/4" MIN. EMBED INTO FILLED BLOCKS (JAMBS)

ANCHOR EDGE DISTANCES

INTO CONCRETE AND MASONRY = 2-1/2" MIN.  
 INTO WOOD STRUCTURE = 1-1/4" MIN.

ANCHOR CL TO CL DISTANCE

INTO CONCRETE = 3" MIN.  
 INTO FILLED BLOCKS = 4" MIN.

TYPE 'B'- 5/16" DIA ULTRACON BY 'ELCO' (Fu=177 KSI, Fy=155 KSI)  
 DIRECTLY INTO CONCRETE  
 1-3/4" MIN. EMBED INTO CONCRETE (HEAD/SILL/JAMBS)

TYPE 'BB'- 5/16" DIA ULTRACON BY 'ELCO' (Fu=177 KSI, Fy=155 KSI)  
 DIRECTLY INTO GROUT FILLED BLOCKS  
 1-3/4" MIN. EMBED INTO FILLED BLOCKS (JAMBS)

ANCHOR EDGE DISTANCES

INTO CONCRETE = 2-3/16" MIN.

ANCHOR CL TO CL DISTANCE

INTO CONCRETE = 3" MIN.  
 INTO FILLED BLOCKS = 5" MIN.

TYPE 'C'- 5/16" DIA. TEKS OR SELF DRILLING SCREWS (GRADE 5 CRS)  
 INTO F.B.C. APPROVED MULLIONS  
 OR  
 INTO METAL STRUCTURES  
 (3) THREADS MIN. PENETRATION BEYOND METAL SUBSTRATE  
 ALUMINUM: 1/8" THK. MIN. (6063-T5 MIN.)  
 STEEL: 1/8" THK. MIN. (Fy = 36 KSI MIN.)  
 (STEEL IN CONTACT WITH ALUMINUM TO BE PLATED OR PAINTED)

ANCHOR EDGE DISTANCES

INTO METAL STRUCTURE = 1/2" MIN.

WOOD AT HEAD, SILL OR JAMBS SG = 0.55 MIN.  
 CONCRETE AT HEAD, SILL OR JAMBS f'c = 3000 PSI MIN.  
 C-90 GROUT FILLED BLOCK AT JAMBS f'm = 2000 PSI MIN.

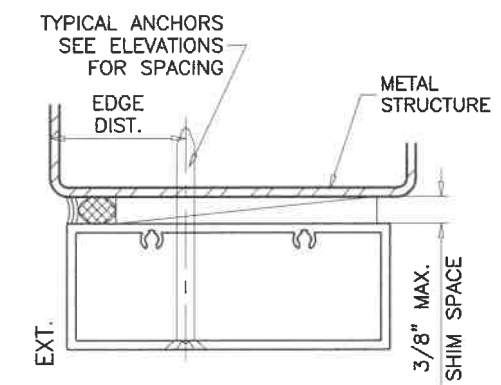
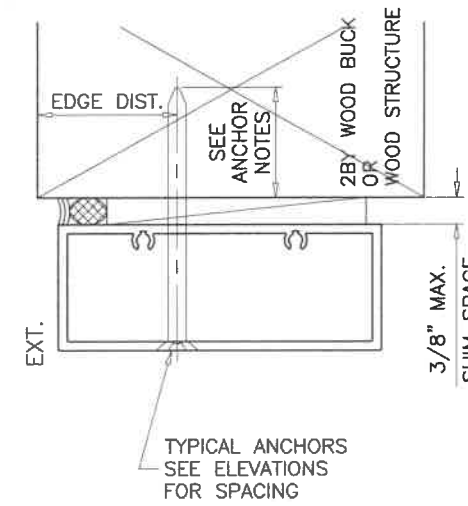
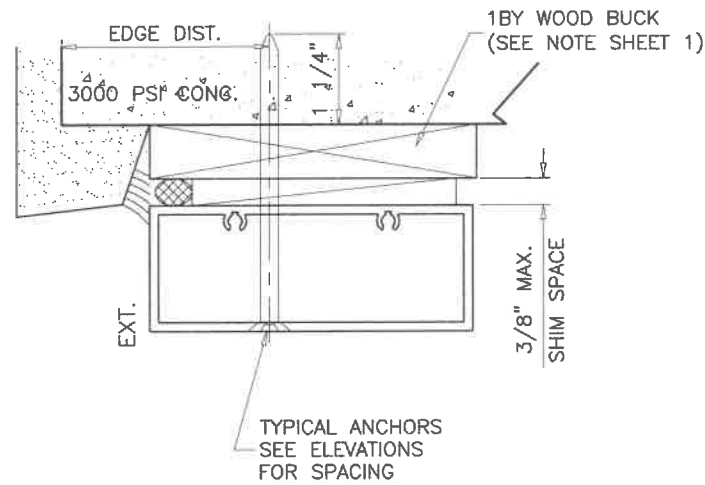

TYPE 'A1'- 1/4" DIA ULTRACON BY 'ELCO' (Fu=177 KSI, Fy=155 KSI)  
 INTO 2BY WOOD BUCKS OR WOOD STRUCTURES  
 1-1/2" MIN. PENETRATION INTO WOOD (HEAD/SILL/JAMBS)  
 THRU 1BY INTO CONC. OR MASONRY  
 1-3/4" MIN. EMBED INTO CONCRETE (HEAD/SILL/JAMBS)  
 1-3/4" MIN. EMBED INTO FILLED BLOCKS (JAMBS)  
 DIRECTLY INTO MASONRY  
 1-3/4" MIN. EMBED INTO FILLED BLOCKS (JAMBS)

ANCHOR EDGE DISTANCES

INTO CONCRETE AND MASONRY = 2-1/2" MIN.  
 INTO WOOD STRUCTURE = 1" MIN.

ANCHOR CL TO CL DISTANCE

INTO CONCRETE = 3" MIN.  
 INTO FILLED BLOCKS = 3" MIN.

TYPE 'B1'- 1/4" DIA ULTRACON BY 'ELCO' (Fu=177 KSI, Fy=155 KSI)  
 DIRECTLY INTO CONCRETE  
 1-3/4" MIN. EMBED INTO CONCRETE (HEAD/SILL/JAMBS)

TYPE 'BB1'- 1/4" DIA ULTRACON BY 'ELCO' (Fu=177 KSI, Fy=155 KSI)  
 DIRECTLY INTO GROUT FILLED BLOCKS  
 1-3/4" MIN. EMBED INTO FILLED BLOCKS (JAMBS)

ANCHOR EDGE DISTANCES

INTO CONCRETE = 2-3/16" MIN.

ANCHOR CL TO CL DISTANCE

INTO CONCRETE = 3" MIN.  
 INTO FILLED BLOCKS = 4" MIN.

TYPE 'C1'- 1/4" DIA. TEKS OR SELF DRILLING SCREWS (GRADE 5 CRS)  
 INTO F.B.C. APPROVED MULLIONS  
 OR  
 INTO METAL STRUCTURES  
 (3) THREADS MIN. PENETRATION BEYOND METAL SUBSTRATE  
 ALUMINUM: 1/8" THK. MIN. (6063-T5 MIN.)  
 STEEL: 1/8" THK. MIN. (Fy = 36 KSI MIN.)  
 (STEEL IN CONTACT WITH ALUMINUM TO BE PLATED OR PAINTED)

ANCHOR EDGE DISTANCES

INTO METAL STRUCTURE = 1/2" MIN.

WOOD AT HEAD, SILL OR JAMBS SG = 0.55 MIN.  
 CONCRETE AT HEAD, SILL OR JAMBS f'c = 3000 PSI MIN.  
 C-90 GROUT FILLED BLOCK AT JAMBS f'm = 2000 PSI MIN.

NOTE: FOR ALL 1/4" DIA. ANCHORS LIMIT SHIMS TO 1/4" MAX.

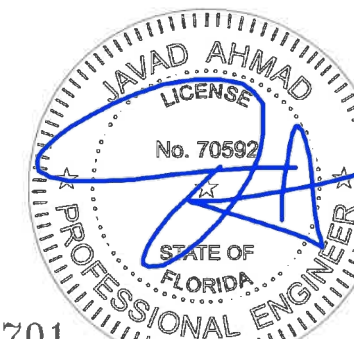

FL #20701

**AL-FAROOQ CORPORATION**  
 ENGINEERS & PRODUCT DEVELOPMENT  
 9360 SUNSET DRIVE, SUITE 220  
 MIAMI, FLORIDA 33173  
 TEL. (305) 264-8100 FAX. (305) 262-6978  
 (C.A.N. 3538)

SERIES EW-350 INSWING ENTRANCE DOOR (L.M.I.)  
**ENVIRALUM INDUSTRIES INC.**  
 5100 N.W. 72 AVENUE BLDG. C  
 MIAMI, FL. 33166  
 TEL. (305) 752-4411 FAX. (305) 406-3877

revisions:	
no	date by description

date: 04-11-17  
 scale: 3/8" = 1"  
 dr. by: TARIQ  
 chk. by:  

drawing no.  
**W17-43**  
 sheet 5.2 of 10

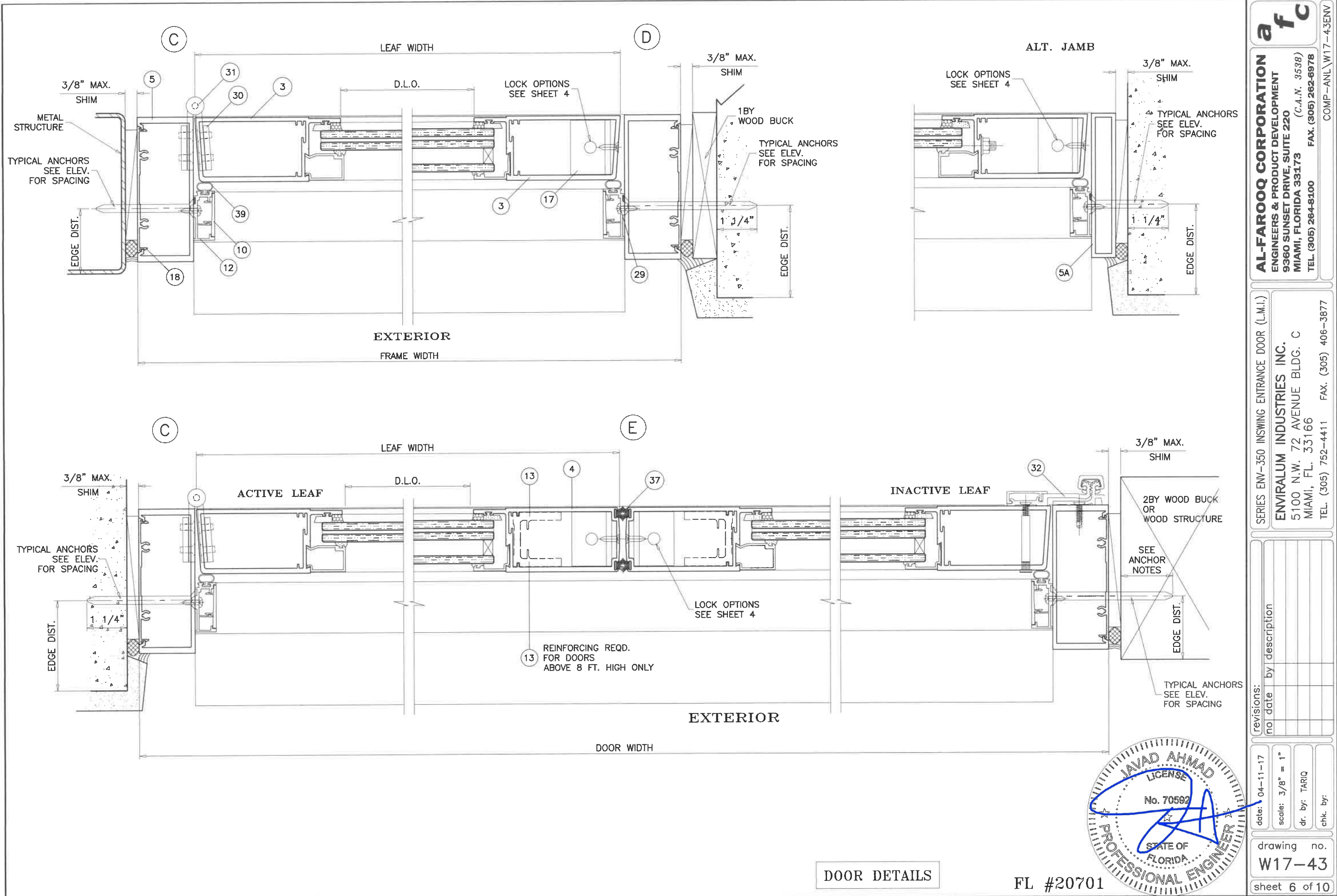

**af c**  
**AL-FAROOQ CORPORATION**  
 ENGINEERS & PRODUCT DEVELOPMENT  
 9360 SUNSET DRIVE, SUITE 220  
 MIAMI, FLORIDA 33173 (C.A.N. 3538)  
 TEL. (305) 264-8100 FAX. (305) 262-6978  
 COMP-ANL \ W17-43ENV

SERIES ENV-350 INSWING ENTRANCE DOOR (L.M.I.)  
**ENVRALUM INDUSTRIES INC.**  
 5100 N.W. 72 AVENUE BLDG. C  
 MIAMI, FL. 33166  
 TEL. (305) 752-4411 FAX. (305) 406-3877

revisions:	
no	date by description

  

date: 04-11-17	scale: 3/8" = 1"	dr. by: TARIQ	chk. by:
drawing no. W17-43			
sheet 6 of 10			

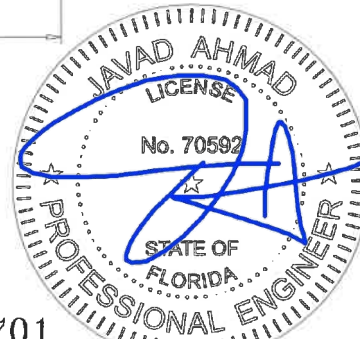

DOOR DETAILS

FL #20701

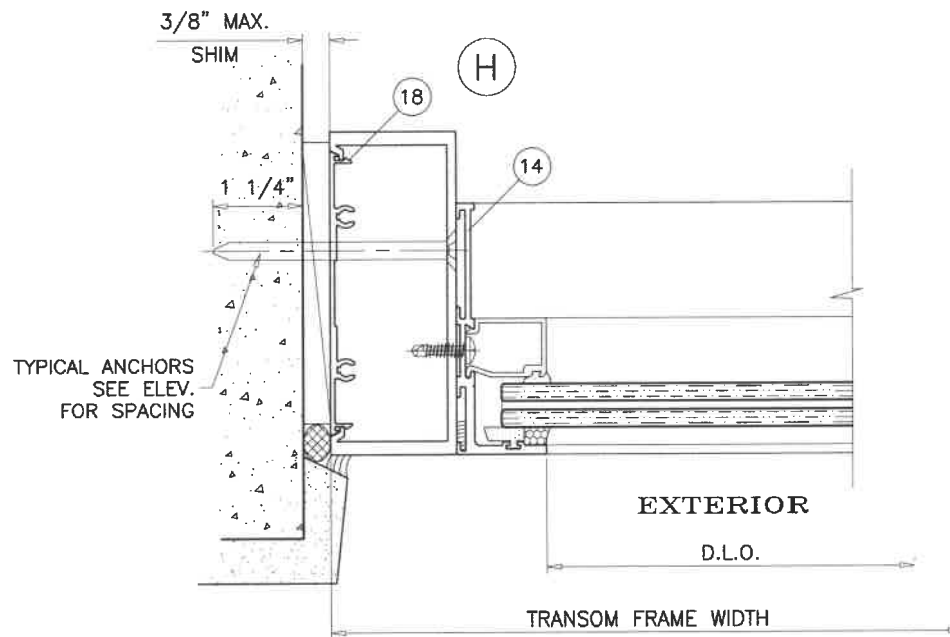
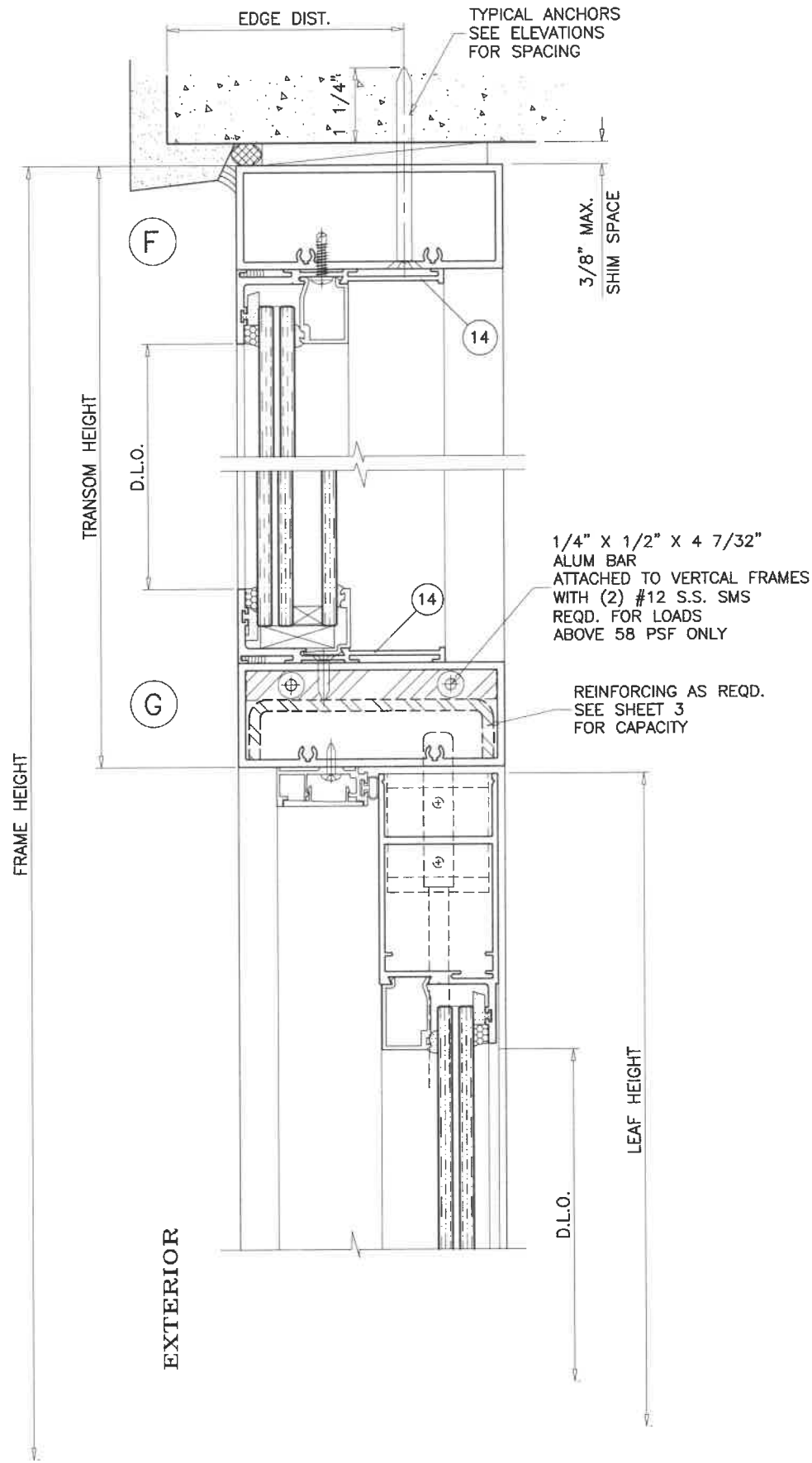

TRANSOM DETAILS

FL #20701

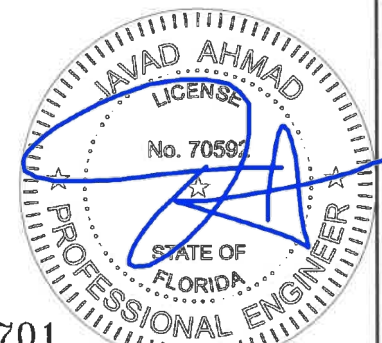

revisions:	no	date	by	description

date: 04-11-17  
 scale: 3/8" = 1"  
 dr. by: TARIQ  
 chk. by:

drawing no.  
**W17-43**  
 sheet 7 of 10

SERIES ENV-350 INSWING ENTRANCE DOOR (L.M.I.)  
**ENVIRALUM INDUSTRIES INC.**  
 5100 N.W. 72 AVENUE BLDG. C  
 MIAMI, FL. 33166  
 TEL. (305) 752-4411 FAX. (305) 406-3877

**AL-FAROOQ CORPORATION**  
 ENGINEERS & PRODUCT DEVELOPMENT  
 9360 SUNSET DRIVE, SUITE 220  
 MIAMI, FLORIDA 33173 (C.A.N. 3538)  
 TEL. (305) 264-8100 FAX. (305) 262-6978  
 COMP-ANL\W17-43ENV

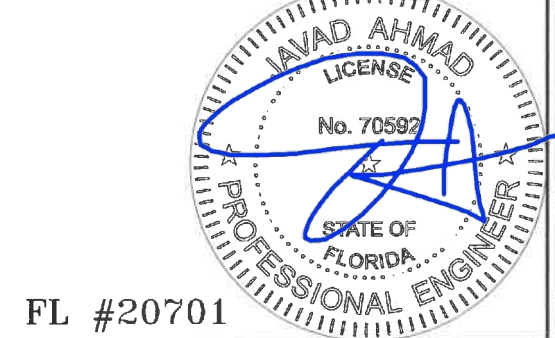
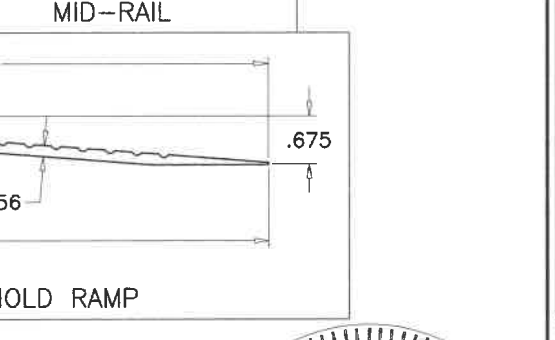
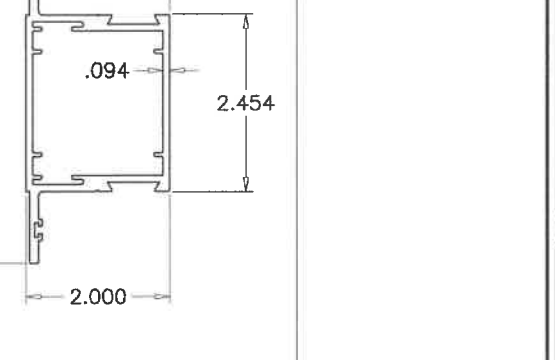
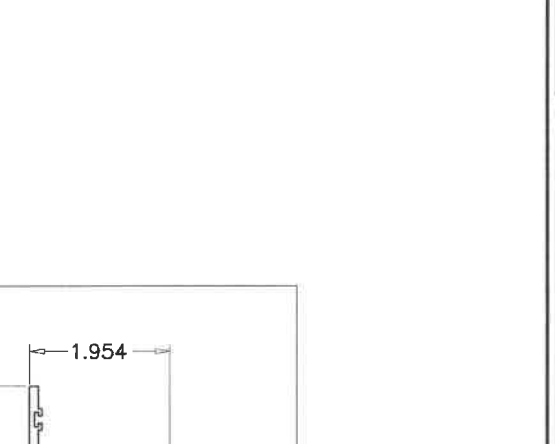
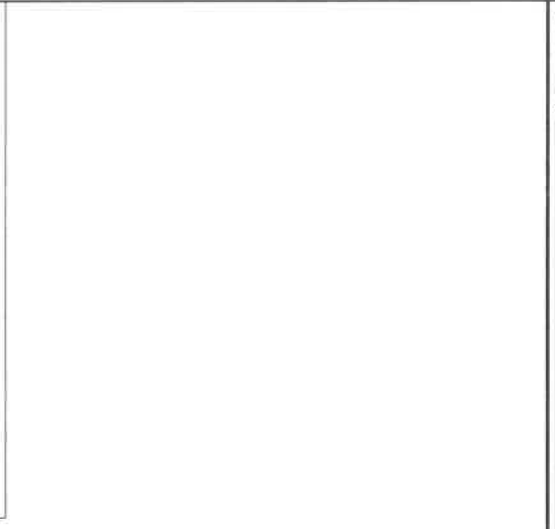
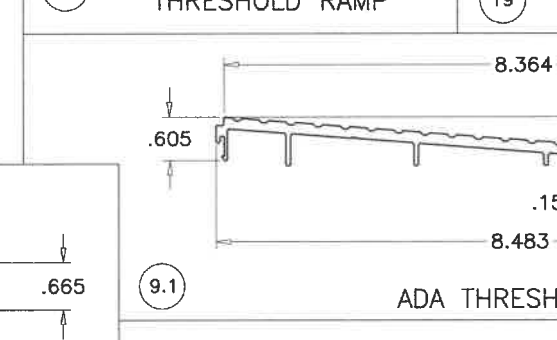
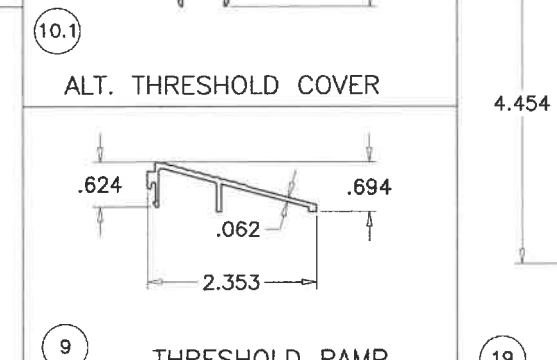
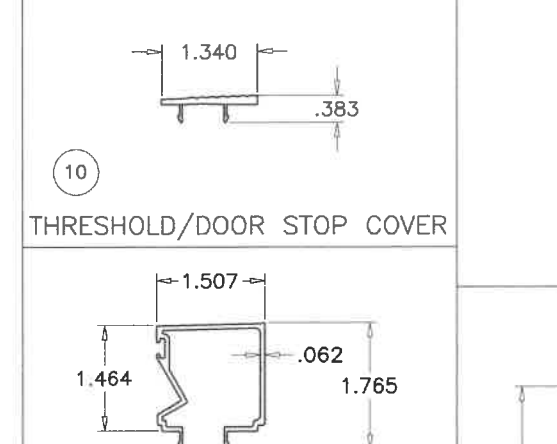
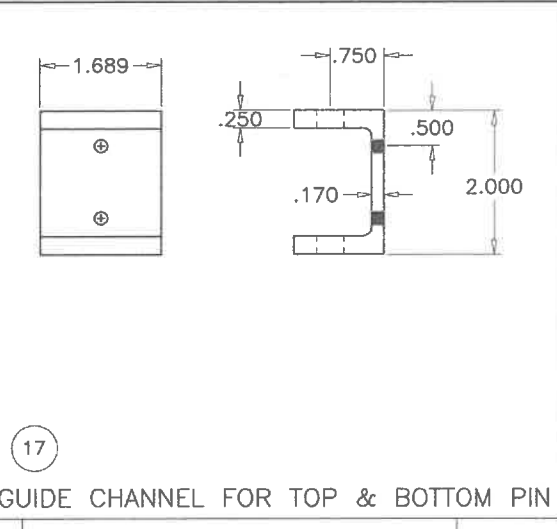
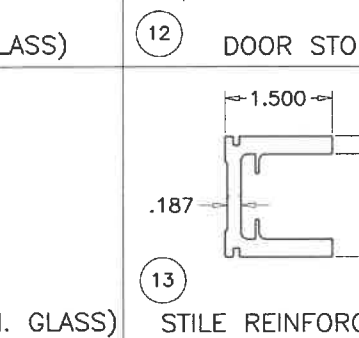
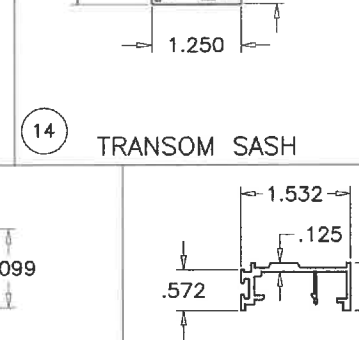
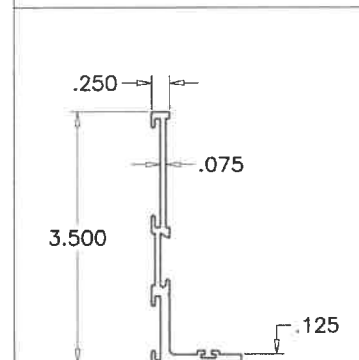
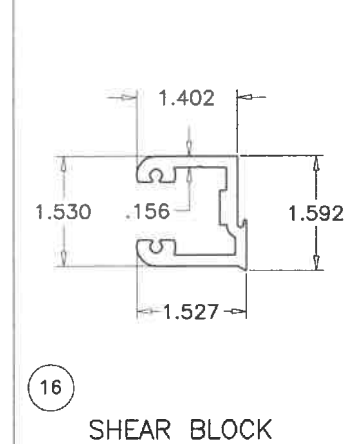
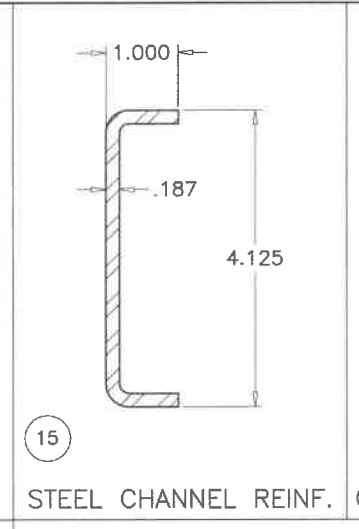
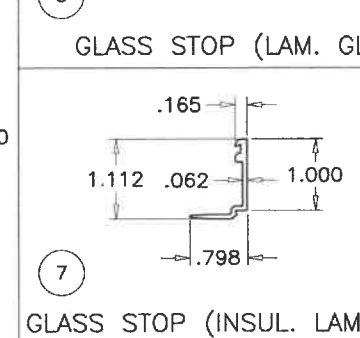
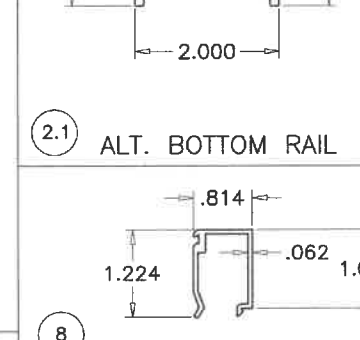
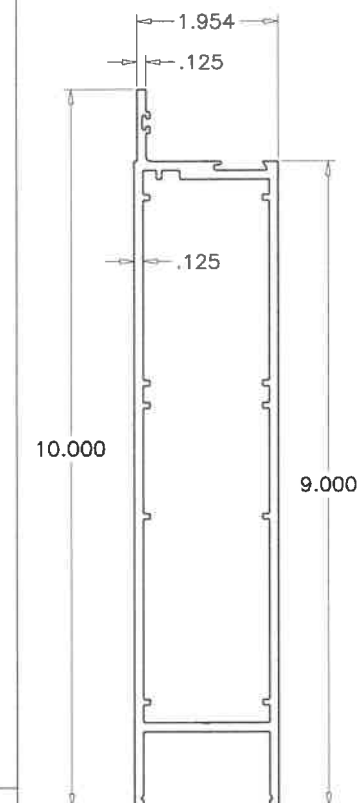
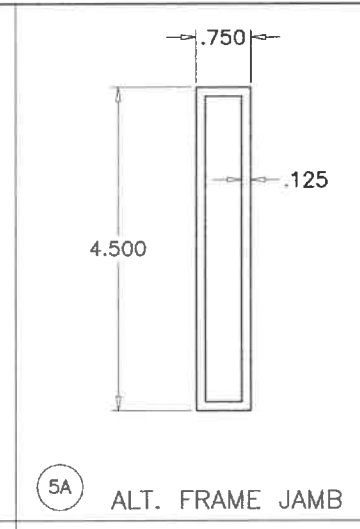
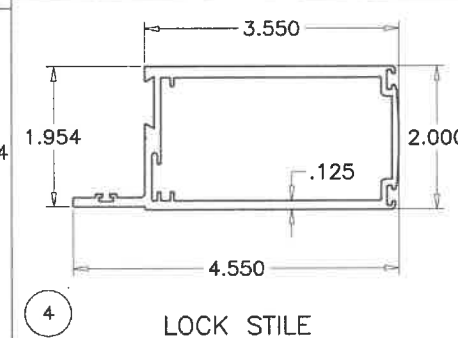
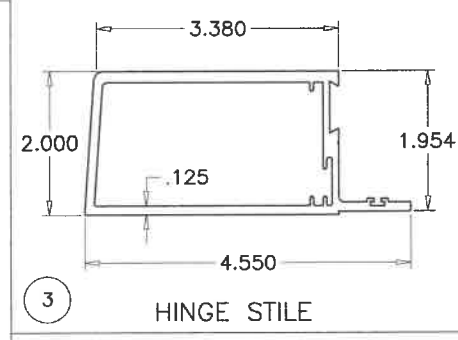
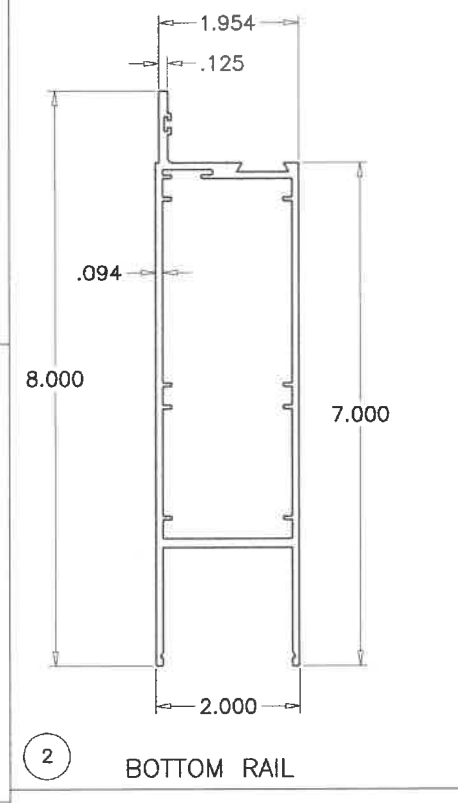
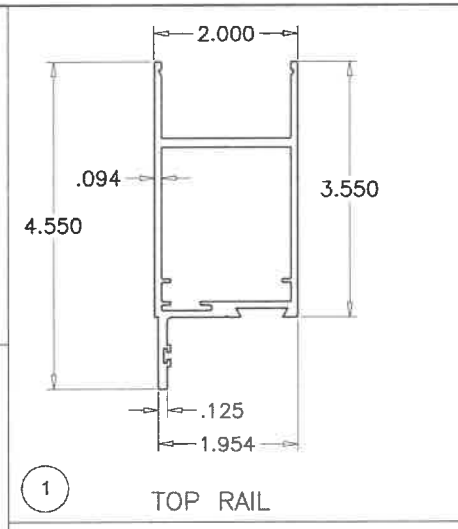
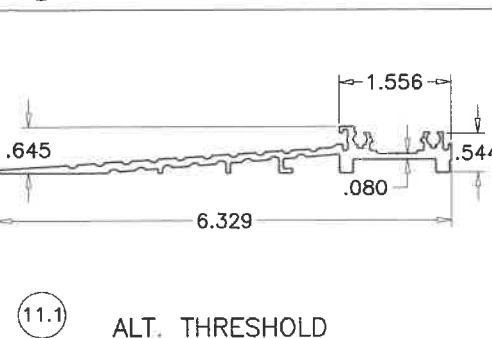
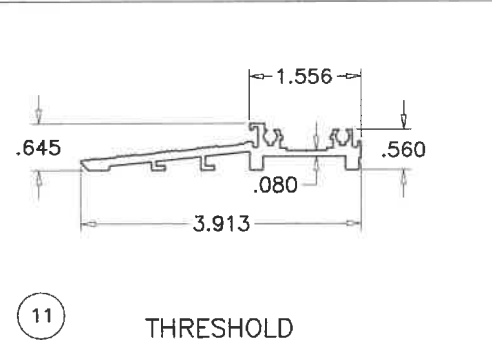
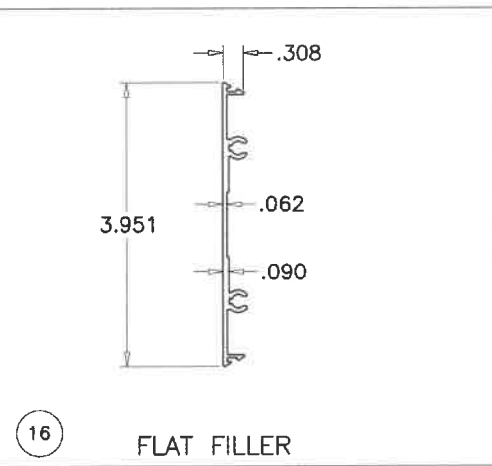
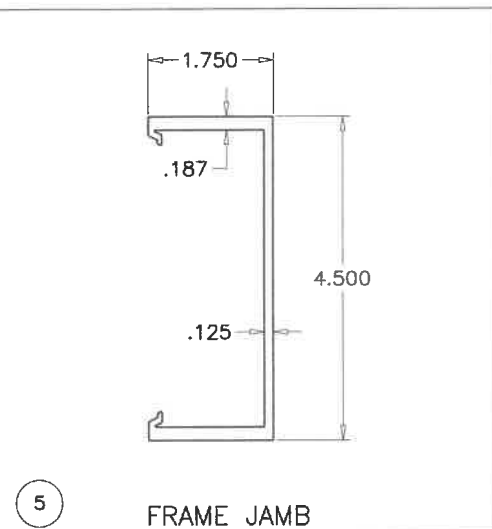
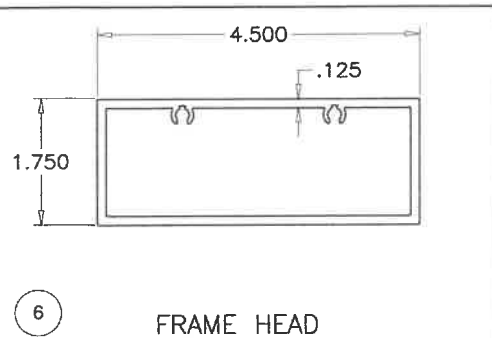

**AL-FAROOQ CORPORATION**  
 ENGINEERS & PRODUCT DEVELOPMENT  
 9360 SUNSET DRIVE, SUITE 220  
 MIAMI, FLORIDA 33173  
 TEL. (305) 264-8100 FAX. (305) 262-6978  
 COMP-ANL \ W17-43ENV

SERIES ENV-350 INSWING ENTRANCE DOOR (L.M.I.)  
**ENVALUM INDUSTRIES INC.**  
 5100 N.W. 72 AVENUE BLDG. C  
 MIAMI, FL. 33166  
 TEL. (305) 752-4411 FAX. (305) 406-3877

no	date	description

date: 04-11-17  
 scale: 3/8" = 1"  
 dr. by: TARIQ  
 chk. by:  
 drawing no. **W17-43**  
 sheet 8 of 10

FL #20701

Sealed 5/10/19

**HINGE OPTION #1:**

4" X 4-1/2" X .130" THK. ST. STEEL KNUCKLE HINGE SERIES 4001 BY 'REGENT HARDWARE' OR SERIES FBB 191 BY 'STANLEY SECURITY SOLUTIONS' OR SERIES TA2314/TA2714 BY 'MCKINNEY ASSA ABLOY' 3 PER LEAF  
 TOP/BOTTOM HINGES AT 7" FROM EACH END  
 CENTER HINGE AT MIDSPAN  
 FASTENED TO  
 FRAME JAMB WITH (4) 12-24 X 1/2" FH MS  
 DOOR STILE WITH (4) 12-24 X 1/2" FH MS

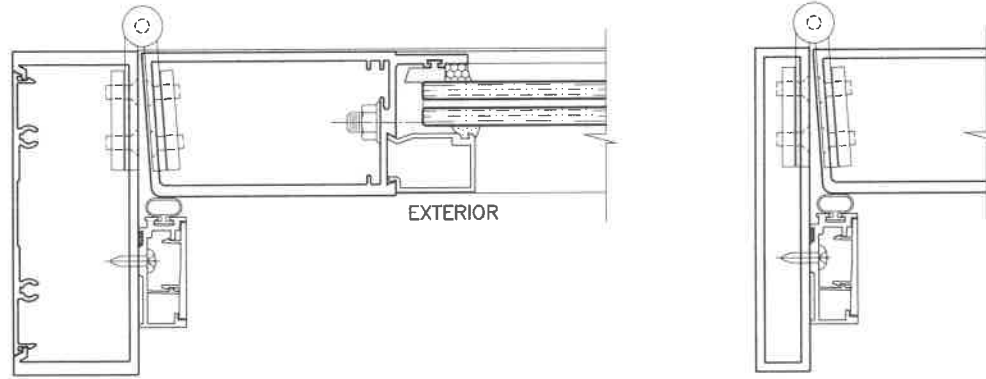

**HINGE OPTION #2:**

CONTINUOUS GEAR ALUMINUM HINGE PEMKO-FS & SELECT SL-21 FASTENED TO  
 FRAME JAMB WITH #12 X 3/4" FH SCREWS AT 6" O.C.  
 DOOR STILE WITH 1/4-20 X 1-1/4" FH MS WITH SEX BOLT AT 6" O.C.

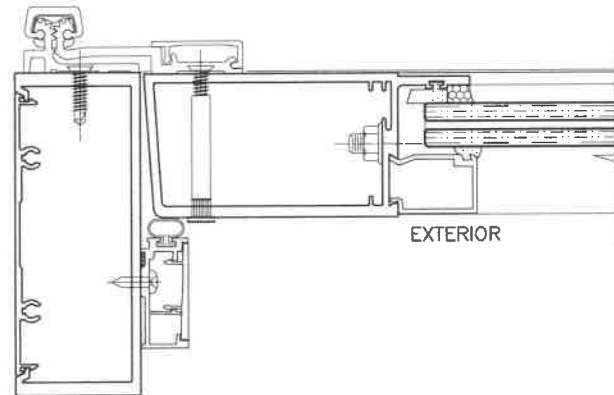

**HINGE OPTION #3:**

CONTINUOUS ALUMINUM ROTTON HINGE 'PEMKO-FM' OR 'SELECT SL 27' FASTENED TO FRAME JAMB AND TO JAMB STILE WITH (22) #12-24 X 1/2" FH MS SCREWS

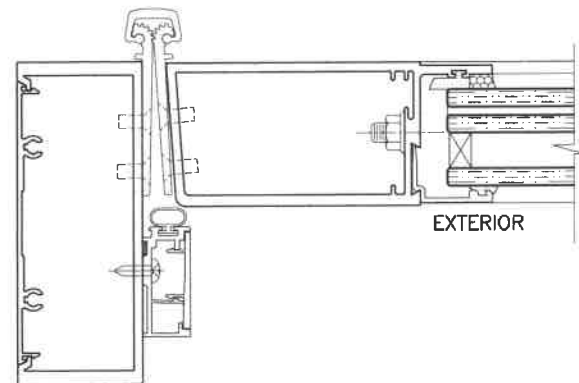

ITEM NO.	PART NUMBER	QUANTITY	DESCRIPTION	MATERIAL	MANF./SUPPLIER/REMARKS
1	ENV-351	1/ LEAF	TOP RAIL	6063-T6	ENVIRALUM
2	ENV-352	1/ LEAF	BOTTOM RAIL	6063-T6	ENVIRALUM
2.1	ENV-3521	1/ LEAF	ALT. BOTTOM RAIL (10" HIGH)	6063-T6	ENVIRALUM
3	ENV-353	1/ LEAF	HINGE STILE	6063-T6	ENVIRALUM
4	ENV-354	1/ LEAF	LOCK STILE	6063-T6	ENVIRALUM
5	ENV-355	2/ DOOR	FRAME JAMB	6063-T6	ENVIRALUM
5A	--	2/ DOOR	ALT. FRAME JAMB	6063-T6	ENVIRALUM
6	ENV-356	1/ DOOR	FRAME HEAD	6063-T6	ENVIRALUM
7	ENV-357	4/ LITE	GLASS STOP (INSULATED GLASS)	6063-T6	ENVIRALUM
8	ENV-358	4/ LITE	GLASS STOP (LAMINATED GLASS)	6063-T6	ENVIRALUM
9	ENV-359	AS REQD.	ADA THRESHOLD RAMP	6063-T6	ENVIRALUM
9.1	ENV-3520	AS REQD.	ADA THRESHOLD RAMP	6063-T6	ENVIRALUM
10	ENV-3510	AS REQD.	THRESHOLD/DOOR STOP COVER	6063-T6	ENVIRALUM
10.1	ENV-3518	AS REQD.	ALT. THRESHOLD COVER (HI-RISE)	6063-T6	ENVIRALUM
11	ENV-3511	1/ DOOR	THRESHOLD	6063-T6	ENVIRALUM
11.1	ENV-3519	1/ DOOR	ALT. THRESHOLD	6063-T6	ENVIRALUM
12	ENV-3512	3/ DOOR	DOOR STOP	6063-T6	ENVIRALUM
13	ENV-3513	AS REQD.	STILE REINFORCEMENT, REQD. FOR DOORS ABOVE 8 FT. HIGH	6063-T6	ENVIRALUM
14	ENV-3515	4/ TRANSOM	TRANSOM SASH	6063-T6	ENVIRALUM
15	ENV-ST2	AS REQD.	1" X 4-1/8" X 1" X 3/16" THK. CHANNEL	STEEL	ENVIRALUM
16	ENV-3516	1/ LEAF CORNER	SHEAR BLOCK	6063-T6	ENVIRALUM
17	ENV-GC01	2/ LEAF	GUIDE CHANNEL FOR TOP & BOTTOM PIN	6063-T6	ENVIRALUM
18	ENV-454	AS REQD.	FLAT SNAP, 3" LONG	6063-T6	ENVIRALUM
19	ENV-3514	AS REQD.	MID-RAIL (OPTIONAL)	6063-T5	ENVIRALUM
21	ENV-G04	AS REQD.	INTERIOR GASKET	EPDM	GLAZING RUBBER PRODUCTS
22	ENV-G06	AS REQD.	SPACER GASKET	EPDM	GLAZING RUBBER PRODUCTS
22A	ENV-G06	1/ QUARTER POINT	SPACER GASKET, 1" LONG	EPDM	GLAZING RUBBER PRODUCTS
23	ENV-SB01	1/ QUARTER POINT	3/8" X 1/2" X 2" SETTING BLOCKS, DUROMETER 80±5	EPDM	GLAZING RUBBER PRODUCTS
24	ENV-SB02	1/ QUARTER POINT	3/8" X 1-1/4" X 2" SETTING BLOCKS, DUROMETER 80±5	EPDM	GLAZING RUBBER PRODUCTS
25	DOW 791	AS REQD.	GLAZING COMPOUND	SILICONE	DOWSIL
26	GE SCS2000	AS REQD.	GLAZING COMPOUND	SILICONE	GE MOMENTIVE
27	#12 X 1-1/2	4/ CORNER	FRAME ASSEMBLY SCREWS	ST. STEEL	HWH SMS, AT 16" O.C.
28	#8 X 5/8"	AS REQD.	TRANSOM SASH SCREWS	ST. STEEL	AT 3" FROM ENDS & 12" O.C.
29	#8 X 5/8"	AS REQD.	DOOR STOP ASSEMBLY SCREWS, @ 3" FROM ENDS & 20" O.C.	ST. STEEL	HWH SMS
30	ENV-BP1	2/ HINGE	HINGE BACKING PLATE, 1-1/2" X 1/4" THK. X 8-3/8" LONG	ALUMINUM	--
31	--	AS REQD.	4-1/2" X 4" BUTT HINGES	ST. STEEL	--
32	SL-21	1/ LEAF	CONT. GEAR HINGE	ALUMINUM	SELECT PRODUCTS LTD.
32A	PEMKO-FS	1/ LEAF	CONT. GEAR HINGE	ALUMINUM	PEMKO
33	1/4-20 X 1"	10/ LEAF	CORNER BLOCK ASSEMBLY	ST. STEEL	HEX HEAD BOLT W/ WASHER
34	ENV-G01	AS REQD.	FIXED INTERIOR GASKET	EPDM	GLAZING RUBBER PRODUCTS
37	ENV-WP1	AS REQD.	WOOL PILE W'STRIPPING	TRILOBAL YARN	ULTRAFAB
38	ENV-WP2	AS REQD.	WOOL PILE W'STRIPPING	TRILOBAL YARN	ULTRAFAB
39	ENV-BG1	AS REQD.	BULB W'STRIPPING, (.475 BULB W/ FLAP X .270 BK.)	EPDM	ULTRAFAB

**SEALANTS:**

ALL FRAME CORNERS, JOINTS, MULLION SEAMS AND PERIMETER OF GLAZING BEAD TO FRAME SEALED WITH SILICONE SEALANT.

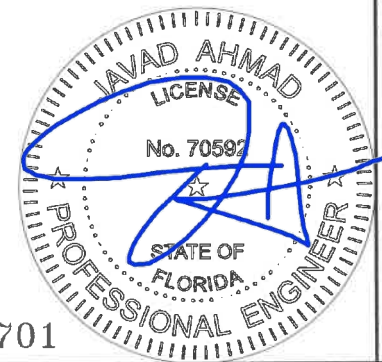

FL #20701

Sealed 5/10/19

**AL-FAROOQ CORPORATION**  
 ENGINEERS & PRODUCT DEVELOPMENT  
 9360 SUNSET DRIVE, SUITE 220  
 MIAMI, FLORIDA 33173  
 TEL. (305) 264-8100 FAX. (305) 262-6978  
 (C.A.N. 3598)  
 COMP-ANL\W17-43ENV

SERIES ENV-350 INSWING ENTRANCE DOOR (L.M.I.)  
**ENVIRALUM INDUSTRIES INC.**  
 5100 N.W. 72 AVENUE BLDG. C  
 MIAMI, FL. 33166  
 TEL. (305) 752-4411 FAX. (305) 406-3877

revisions:  
 no date by description

date: 04-11-17  
 scale: 3/8" = 1"  
 dr. by: TARIQ  
 chk. by:

drawing no.  
**W17-43**

sheet 9 of 10



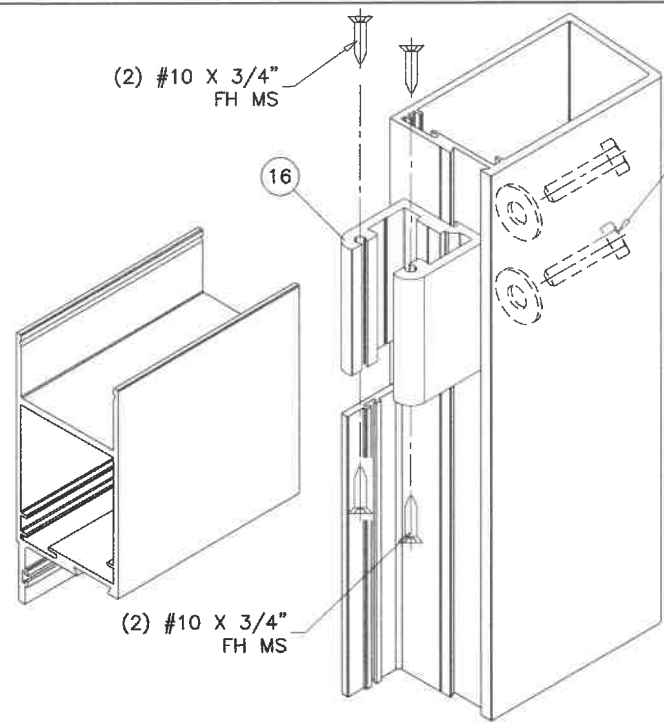

DOOR LEAF TOP CORNER

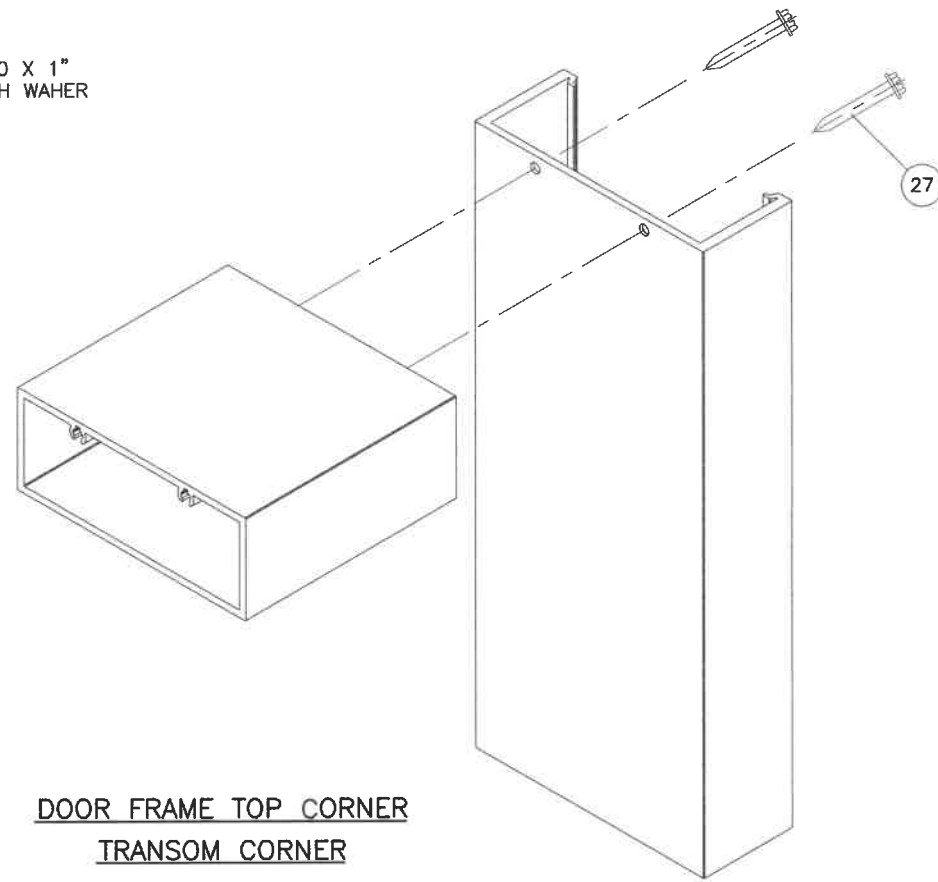

DOOR FRAME TOP CORNER  
TRANSOM CORNER

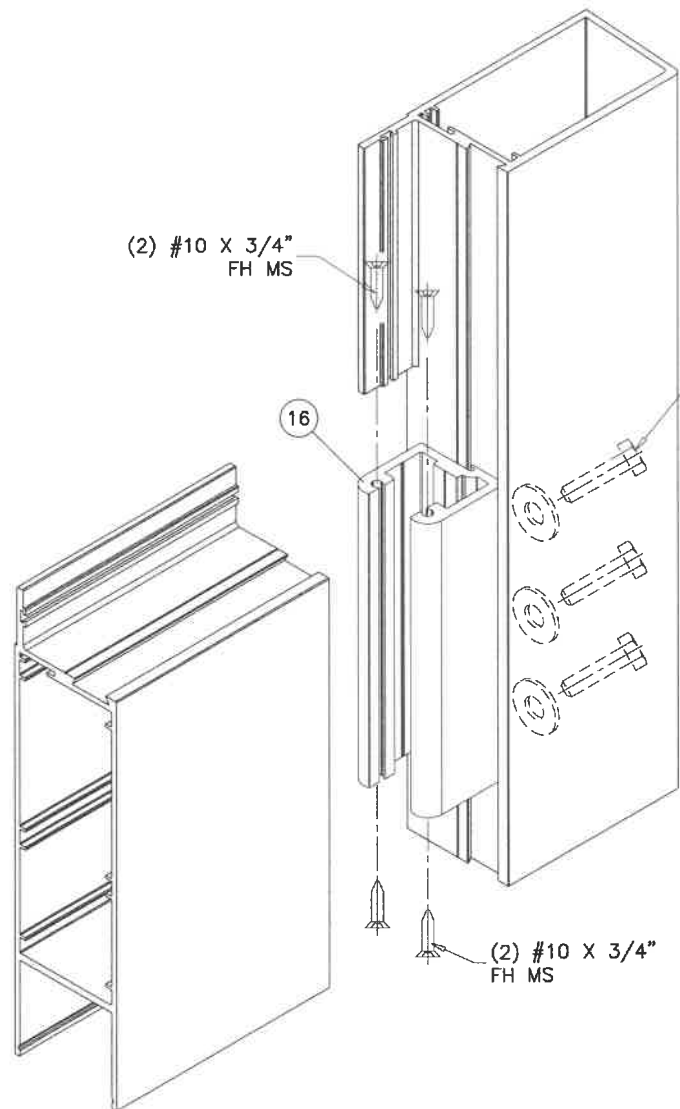

DOOR LEAF BOTTOM CORNER

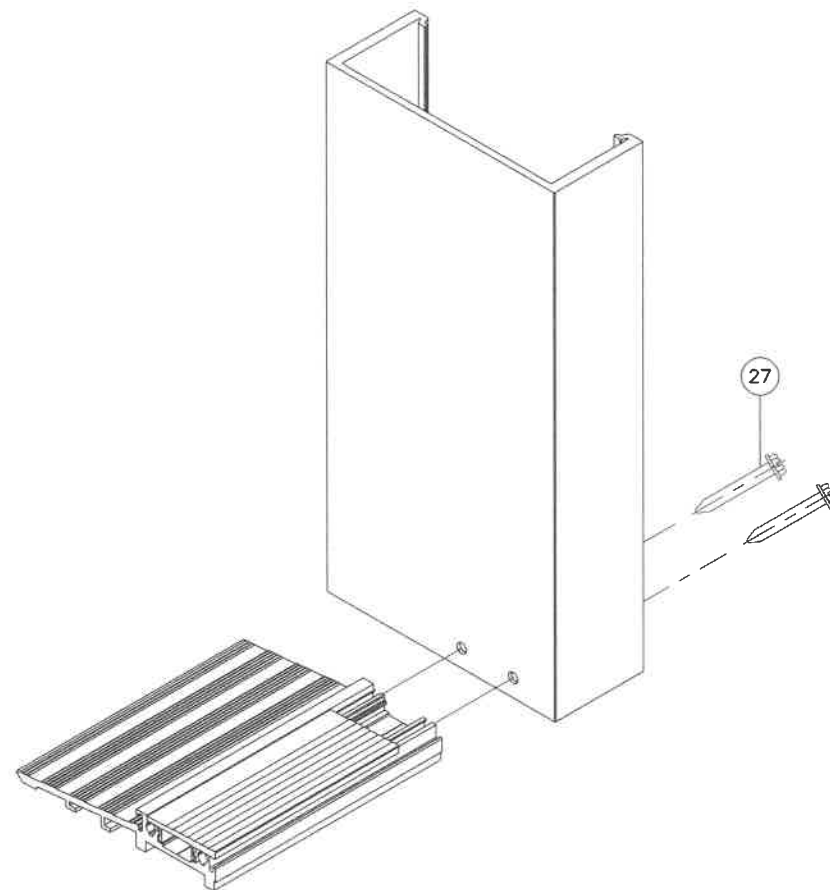

DOOR FRAME BOTTOM CORNER

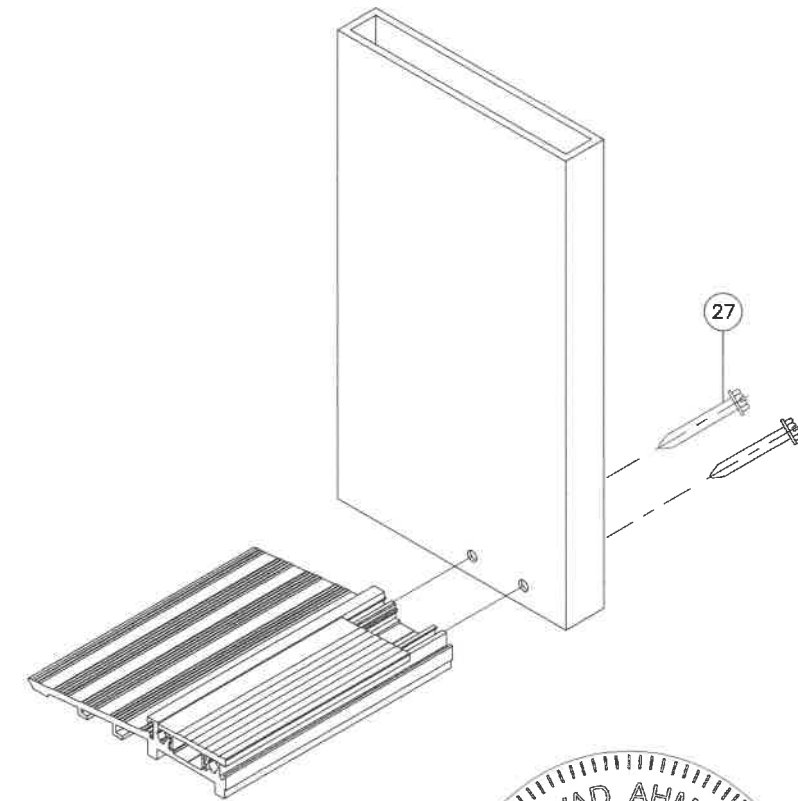

FL #20701

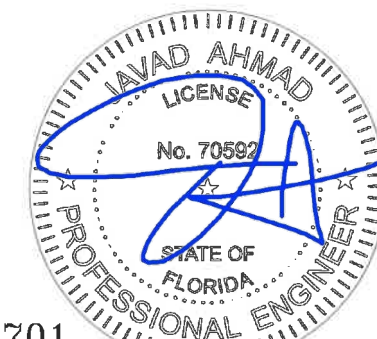

**a f c**  
**AL-FAROOQ CORPORATION**  
 ENGINEERS & PRODUCT DEVELOPMENT  
 9360 SUNSET DRIVE, SUITE 220 (C.A.N. 3538)  
 MIAMI, FLORIDA 33173 TEL. (305) 262-6978  
 TEL. (305) 264-8100 FAX. (305) 262-6978  
 COMP-ANL\W17-43ENV

SERIES ENV-350 INSWING ENTRANCE DOOR (L.M.I.)  
**ENVIRALUM INDUSTRIES INC.**  
 5100 N.W. 72 AVENUE BLDG. C  
 MIAMI, FL. 33166  
 TEL. (305) 752-4411 FAX. (305) 406-3877

revisions:	no	date	by	description

date: 04-11-17  
 scale: 3/8" = 1"  
 dr. by: TARIQ  
 chk. by:

drawing no.  
**W17-43**  
 sheet 10 of 10